

Raziskava zdrsa v mehanizmu med valjem in trakom

An Investigation of Slipping in Rolamite-Type Mechanisms

Ričardas Viktoras Ulozas

V tem prispevku obravnavamo dve vrsti zdrsa v natančnem mehanizmu med valjem in trakom, imenovanim "Rolamite" tračni mehanizem (oblikovno in vzmetno drsenje).

Dva valja sta povezana s prilagodnim trakom v mehanizmu, tako da je povezava med njima le preko prilagodnega traku, katerega konca sta pritrjena na usmerjevalni ravnini.

V mehanizmu pride do oblikovnega zdrsa, ki zavisi od debeline traku. Izravnavo oblikovnega drsenja dosežemo z uporabo dodatnih valjev, katerih usmeritev je nasprotna usmeritvi obeh glavnih valjev.

Obravnavamo tudi vpliv prostih koncev prilagodnega traku na natančnost nastavitve mehanizma. Podane so računske enačbe za odmero in izračun vzmetnega drsenja "Rolamite" tračnega mehanizma. Dokazana je povezava med raztezkom prostih koncev in odpornimi silami gibanja. Vrednost vzmetnega zdrsa je neposredno odvisna od odpornih sil, amplitude gibanja in lege nihajnega središča. Podana je shema izravnave zdrsa. Izpeljane so računske zveze, ki dovoljujejo določanje parametrov vzmetne izravnave z izločitvijo vzmetnega drsenja.

© 2004 Strojniški vestnik. Vse pravice pridržane.

(Ključne besede: mehanizmi Rolamite, zdrsanje, drsenje oblikovno, drsenje vzmetno, kompenzatorji)

This paper looks at two variants of slipping that exist in precision roller-band mechanisms (PRBM), such as a Rolamite-type mechanism (geometric and springy slipping).

The rollers are wrapped by a flexible band in the mechanisms and contacted between themselves only through a flexible band, the ends of which are attached to the directing planes of the rolamite type mechanism (RTM).

In the PRBM there is geometric sliding, the value of which is influenced by the thickness of the flexible band. Compensation of the geometric sliding can be achieved by introducing additional band-wrapping rollers, the direction of which is opposite to the main band's direction.

The influence of the flexible band's free ends on the accuracy of the positioning of the mechanism is reviewed. The calculation scheme of the mechanism for the measurement and calculation of springy slipping of RTM units is presented and described by equations. It is established that the springy slipping in the RTM is connected to the strain of the free band's pieces from the resistance forces of motion. The value of springy slipping directly depends on the resistance force, the amplitude of motion and the value of the coordinate of the swinging centre. The scheme of a compensator of the springy slipping is presented. The calculation relations permitting us to define the parameters of spring-compensator, eliminating springy slipping, are deduced.

© 2004 Journal of Mechanical Engineering. All rights reserved.

(Keywords: Rolamite type mechanisms, geometrical slipping, springy slipping, compensators)

0 INTRODUCTION

Donald F. Wilkes invented the precision roller-band mechanism, called the Rolamite (roller + mite) type mechanism (RTM) in 1967 ([1] and [2]). The RTM rollers are wrapped around by a flexible band with high tension at a large angle (usually $>180^\circ$); the contact is made through a flexible band, which is at-

tached by stretching the ends to two direct surfaces.

Papers [1] to [3] indicate that the RTM is a precision mechanism, the elements of which are moving without slipping with respect to one another. However, the authors of the paper [4] indicate that the rollers in a RTM slip under some particular conditions, but they do not present a theoretical explanation for it.

The band wraps around all the rollers (such as the RTM or scroller) in precision roller-band mechanisms (PRBM). Thus, possible geometrical slipping is stipulated by the presence of a flexible transmission element (a band with finite thickness). Geometrical slipping, i.e., relative displacement of the touching spots in friction mechanisms, depends on the form of the interacting bodies in the zone of their contact.

The purpose of the paper is to find out how the slipping can be compensated in precision roller-band mechanisms.

1 THEORETICAL RESEARCH OF GEOMETRICAL SLIPPING IN ROLLER-BAND MECHANISMS

Let us research a component characteristic of a Rolamite mechanism and that of a scroller, which consists of two cylindrical rollers and a flexible band that is wrapped around them from the opposite sides (Fig. 1).

It is assumed that the band with the rollers, affected by external force, form a roller mechanism with a very tight geometry; elements of the mechanism contact in the line of the centres of the rollers. The contact load of the rollers and the bands affects the kinematics of the mechanisms discussed, because movement is performed in the points of contact transfer.

Let the band *l* move from the “feeding” roller 2, with radius \tilde{R}_2 , to the “receiving” roller 3, with

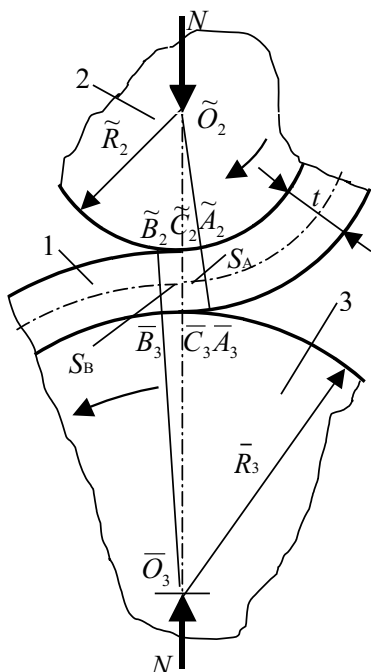

Fig. 1. Schematics of the PRBM mechanism discussed to determine the geometrical slipping of the elements

radius \bar{R}_3 . The “feeding” elements of the roller-band mechanism (the roller or the deflective plane) are marked as “~”, and the “receiving” elements are marked as “-”.

The section $\tilde{A}_2 \bar{A}_3$ moves to position $\tilde{B}_2 \bar{B}_3$ over their contact zone and becomes a natural extension of the lines $\tilde{O}_2 \tilde{A}_2$ and $\bar{O}_3 \bar{B}_3$.

Let us examine the movement of band *l* in the contact zone of elements 2 and 3.

The distance of the sections from the centre line $\tilde{O}_2 \bar{O}_3$ to the border of the contact zone is marked $S_A + S_B$, the thickness of the band *l* is marked as *t*. The value of the expression $S_A + S_B$ depends on the material flexibility of the contacting elements 2-*l*-3, the radius \tilde{R}_2 and \bar{R}_3 of the elements 2 and 3, and the value of the normal load *N*. Moreover, compression deformations occur when an external load influences the contact zone of the elements, and their resultant force passes through the rolling axis of the rollers. Redistribution of the deformations occurs in the contact points when the mechanism loaded with force *N* is rolling. As a result, the point where the resultant force operates moves towards the rolling side by a distance *k*. The reason for such redistribution of the deformations is the elastic ridges on the bodies’ surface. Rolling damping forces perform the work, used for their formation.

Then, according to Fig. 1 it is assumed that

$$S_A = S_0 + k; S_B = S_0 - k; S_A + S_B = 2 S_0 \quad (1),$$

k - coefficient of rolling damping,
 $2S_0$ - contact’s width.

It is assumed that

$$\min(\tilde{R}_2; \bar{R}_3) \gg t; \min(\tilde{R}_2; \bar{R}_3) \gg S_0 > k \quad (2).$$

Satisfactorily reliable values $\tilde{B}_2 \tilde{C}_2, \tilde{C}_2 \tilde{A}_2, \bar{B}_3 \bar{C}_3, \bar{C}_3 \bar{A}_3$, and the displacement sector of each roller 2 and 3 in the contact zone, were found from the quadrangle $\tilde{A}_2 \tilde{B}_2 \bar{B}_3 \bar{A}_3$ after evaluating the smallness row of the accessed values:

$$\begin{aligned} \tilde{B}_2 \tilde{C}_2 &= S_B \frac{\bar{R}_3 + t}{\bar{R}_3 + \frac{t}{2}}; & \tilde{C}_2 \tilde{A}_2 &= S_A \frac{\tilde{R}_2}{\tilde{R}_2 + \frac{t}{2}} \\ \bar{B}_3 \bar{C}_3 &= S_B \frac{\bar{R}_3}{\bar{R}_3 + \frac{t}{2}}; & \bar{C}_3 \bar{A}_3 &= S_A \frac{\tilde{R}_2 + t}{\tilde{R}_2 + \frac{t}{2}} \end{aligned} \quad (3).$$

When section $\tilde{A}_2 \bar{A}_3$ moves over into position $\tilde{B}_2 \bar{B}_3$, the roller 2 surface will move over \tilde{x} , and the roller 3 surface will move over \bar{x} :

$$\begin{aligned} \tilde{x} &= \tilde{B}_2 \tilde{C}_2 + \tilde{C}_2 \tilde{A}_2 = \frac{(S_0 - k)(\bar{R}_3 + t)}{\bar{R}_3 + \frac{t}{2}} + \frac{(S_0 + k)\tilde{R}_2}{\tilde{R}_2 + \frac{t}{2}} \\ \bar{x} &= \bar{B}_3 \bar{C}_3 + \bar{C}_3 \bar{A}_3 = \frac{(S_0 - k)\bar{R}_3}{\bar{R}_3 + \frac{t}{2}} + \frac{(S_0 + k)(\tilde{R}_2 + t)}{\tilde{R}_2 + \frac{t}{2}} \end{aligned} \quad (4).$$

The flexible band l will move over:

$$2S_0 = \frac{\tilde{x} + \bar{x}}{2} \quad (5)$$

The band l is moved over an infinitively small value ds and the rollers 2 and 3 are moved over $d\tilde{x}$ and $d\bar{x}$ respectively.

Considering that:

$$d\tilde{x} = \tilde{x} \frac{ds}{2S_0}; \quad d\bar{x} = \bar{x} \frac{ds}{2S_0} \quad (6)$$

the movements of the rollers 2 and 3 ($d\tilde{x}$ and $d\bar{x}$) conform to the movement of the flexible band l (ds) when:

$$\frac{t}{R} \ll 1 \quad (7)$$

can be expressed like:

$$d\tilde{x} = \left[\frac{(S_0 - k)(\tilde{R}_3 + t)}{\tilde{R}_3 + \frac{t}{2}} + \frac{(S_0 + k)\tilde{R}_2}{\tilde{R}_2 + \frac{t}{2}} \right] \frac{ds}{2S_0} = \frac{1}{2} \left[\frac{(1 - \frac{k}{S_0})(1 + \frac{t}{\tilde{R}_3})}{1 + \frac{t}{2\tilde{R}_3}} + \frac{1 + \frac{k}{S_0}}{1 + \frac{t}{2\tilde{R}_2}} \right] ds \quad (8)$$

Accordingly, Equation (7) can be written as

$$\frac{t}{2\tilde{R}_3} \ll 1; \quad \frac{t}{2\tilde{R}_2} \ll 1 \quad (9)$$

After a variation of these small values the following equation is derived:

$$d\tilde{x} = \left[1 + \frac{t}{4} \left(\frac{1}{\tilde{R}_3} - \frac{1}{\tilde{R}_2} - \frac{k}{\tilde{R}_3 S_0} - \frac{k}{\tilde{R}_2 S_0} \right) \right] ds \quad (10)$$

Disregarding the squares of the small values it becomes:

$$d\tilde{x} \cong \left[1 + \frac{t}{4} \left(\frac{1 - \frac{k}{S_0}}{\tilde{R}_3} - \frac{1 + \frac{k}{S_0}}{\tilde{R}_2} \right) \right] ds \quad (11)$$

Analogously

$$d\bar{x} \cong \left[1 - \frac{t}{4} \left(\frac{1 - \frac{k}{S_0}}{\tilde{R}_3} - \frac{1 + \frac{k}{S_0}}{\tilde{R}_2} \right) \right] ds \quad (12)$$

It can be marked

$$m = \frac{k}{S_0} \text{ - coefficient of contact} \quad (13)$$

and changes with the conversion of signs are performed:

$$d\tilde{x} = \left[1 - \frac{t}{4} \left(\frac{1+m}{\tilde{R}_2} - \frac{1-m}{\tilde{R}_3} \right) \right] ds \quad (14)$$

$$d\bar{x} = \left[1 + \frac{t}{4} \left(\frac{1+m}{\tilde{R}_2} - \frac{1-m}{\tilde{R}_3} \right) \right] ds \quad (15)$$

If it is assumed that

$$\delta = \frac{t}{4} \left(\frac{1+m}{\tilde{R}_2} - \frac{1-m}{\tilde{R}_3} \right) \quad (16)$$

then the measurable displacement of the respective rollers in the contact zone is

$$d\tilde{x} = (1 - \delta) ds; \quad d\bar{x} = (1 + \delta) ds \quad (17)$$

where δ represents the kinematical coefficient of slipping.

Equations (17) show that the rollers, in relation to the band, slip to the opposite direction (Fig. 1). The slipping of both rollers, if viewed from an absolute point, is single-sided, but the movement of the band "feeding" roller 2 (with \tilde{R}_2) becomes slower, because slipping is oriented to a direction opposite to the rolling, meanwhile the "receiving" roller 3 (with \tilde{R}_3) - speeds up. When the moving is in the opposite direction, the roller "feeding" band becomes the "receiving" band, and the "receiving" band become the "feeding" band, their slipping direction does not change. It can be concluded that there exists kinematically irreversible geometrical slipping of the elements of the PRBM mechanism when the radii of the rollers are freely chosen.

The kinematical coefficient of slipping δ is different for opposite displacements of the rollers, because the radii values of the band "feeding" and "receiving" the rollers in Equation (16) exchange. It can be seen (16) that δ is determined by the geometrical characteristics of the mechanism discussed, but the thickness t of the flexible band essentially influences the geometrical slipping value of its elements

Equation (16) for identical rollers would be:

$$\delta = \frac{mt}{2R} \quad (18)$$

2 COMPENSATION OF GEOMETRICAL SLIPPING IN ROLLER-BAND MECHANISMS

A straight-line reversionary movement of a roller wrapped with a flexible band and rolling over a plane without slipping in the zone of contact is

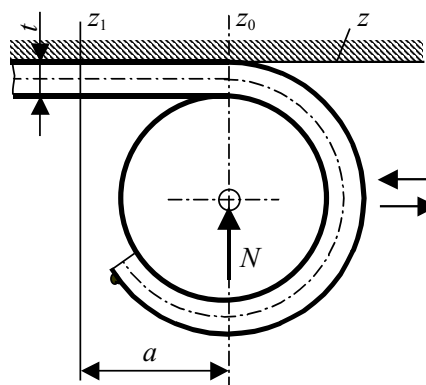

Fig. 2. Schematic diagram of a roller-band mechanism used to examine geometrical slipping

examined using theoretical conclusions about the causes of the geometrical slipping of PRBM elements (Fig. 2)

The roller with the band displaces from position z_1 into position z_0 and “feeds” the band. The flat joint of the mechanism will become the “receiving” band, and according to Equations (17), when $dz > 0$, the equation of the roller displacement depending on the band displacement is:

$$dz = (1 + \delta_1)ds \quad (19),$$

- z – longitudinal displacement of the roller;
- s – displacement of the band;
- δ_1 – kinematical coefficient of slipping (rightward movement)

When $dz < 0$, the flat joint becomes the “feeding” band and the dependence will be :

$$dz = (1 - \delta_2) ds' \quad (20),$$

- δ_2 – kinematical coefficient of slipping (leftward movement)

Taking into account that δ_1 and δ_2 are small values, the dependences of displacement of the band (in each case) will be:

$$ds = (1 - \delta_1)dz; \quad ds' = (1 + \delta_2)dz \quad (21).$$

After integrating:

$$s_1 - s_0 = (1 - \delta_1)(z_1 - z_0) \quad (22),$$

$$s'_0 - s_1 = (1 + \delta_2)(z_0 - z_1) \quad (23).$$

After the completion of Equations (22) and (23) it is found:

$$s'_0 - s = (z_1 - z_0)(-\delta_1 - \delta_2) \quad (24),$$

$$\Delta s = -a(\delta_1 + \delta_2) \quad (25),$$

- a – amplitude of displacement of the roller;
- Δs – magnitude of the band displacement in one cycle of roller rolling;
- “–” indicates that the direction of displacement is opposite to the direction of z

The values of δ_1 and δ_2 in Equation (16), taking into account that the radius of one roller $R = \infty$ (plane) are:

$$\delta_1 = \frac{t}{4} \cdot \frac{1+m}{R}; \quad \delta_2 = -\frac{t}{4} \cdot \frac{1-m}{R} \quad (26),$$

$$\delta_1 + \delta_2 = \frac{tm}{2R}; \quad \Delta s = -\frac{atm}{2R} \quad (27).$$

The irreversibility of the geometrical slipping of the PRBM elements towards the direction of the movement and to compensate such slipping was evaluated and it was suggested to use an addi-

onal flexible joint in the mechanism – a band – which would wrap the roller from the opposite side. That would make it possible to get constant transfer dependences between the angular and linear displacements of the elements and thus to compensate for the geometrical slipping between the elements of the mechanism.

The schematics of a mechanism in which geometrical slipping between the elements is compensated is given in Fig. 3. The roller wrapped with two bands from the opposite sides is moving on the plane z . The bands are stretched with force T , and the roller is loaded with force N , and that ensures tight contact of the contacting elements.

Taking into account that the roller is wrapped with two bands, there exists a possibility to examine the contact of the kinematical pair “roller–plane” as “band-feeding” and “band-receiving” at the same time.

According to the direction of the movement such dependences are:

$$\Delta s_1 = -a(\delta_1 + \delta_2) \quad (28),$$

$$\Delta s_2 = a(\delta_1 + \delta_2) \quad (29).$$

The total result of the dependences (28) and (29) will be zero:

$$2\Delta s = \Delta s_1 + \Delta s_2 = 0$$

which proves that it is possible to compensate for the geometrical slipping between the elements by wrapping the roller with two bands of opposite direction.

Dependences (28) and (29) may differ not by their sign only, but also by the values of kinematical coefficients, according to different conditions of forward and backward movement. In this case the values of deviation may be different from zero, they are equal to the absolute magnitude, and are opposite in sign.

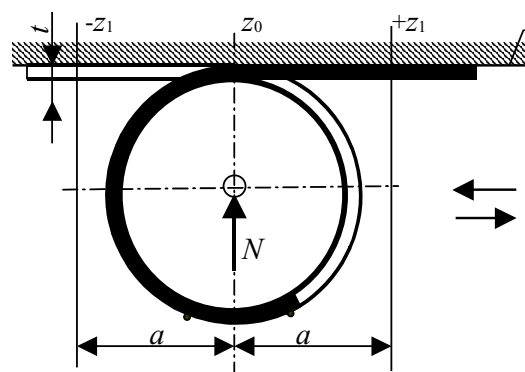

Fig. 3. Compensation of geometrical slipping in roller – band mechanisms

The original roller-band mechanisms with compensation of the geometrical slipping were invented ([5] and [6]), and designed on the grounds of the conclusions in the work about existing geometrical slipping between the elements of the roller-band mechanisms, together with a theoretical study about the possibility to compensate for such slipping.

3 SPRINGY SLIPPING IN RTM

Geometrical slipping is stipulated by the presence of a flexible transmission element (the band with finite thickness). As a compensating link that eliminates the geometrical slipping in RTM, using a complementary band and wrapping the measurement roller at the opposite side from the main band is proposed and motivated.

Considering the complex nature of the interaction of elements of RTM ([1] to [6]), it is reasonable to consider the nature of influence of the free ends of the springy band on which the Rolamite unit moves, on the positioning precision of the mechanism.

The calculations scheme of the mechanism, which consists of the rigid frame 1 and stretch band 3 attached to it (by its pieces), is presented in Fig. 4.

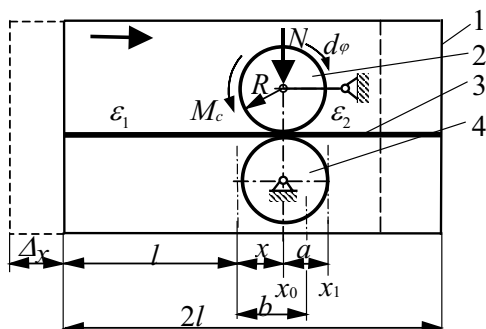

Fig. 4. Calculation scheme of a mechanism for the motivation and calculation of the springy slipping of its elements

Rollers 2 and 4 are revolving on the bearings and have a possibility to roll along the band 3 without slipping. The normal force N connects rollers 2 and 4 with the band 3. Let frame 1 go along band 3 to the left. Rollers 2 and 4 inevitably will resist the motion, and the pieces of the band 3, till both sides from the roller unit deform. The relative strain of the band's pieces is equal according to ε_1 and ε_2 .

According to Fig. 4, it is possible to set up a system of differential equations:

$$\left. \begin{aligned} d\varepsilon_1 &= \frac{dx - Rd\varphi(1 + \varepsilon_1 - \varepsilon_2)}{l + x} \\ d\varepsilon_2 &= \frac{Rd\varphi - dx}{l - x} \\ \varepsilon_2 - \varepsilon_1 &= \mu = \frac{M_c}{Rc} \end{aligned} \right\} \quad (30)$$

- x – value of the frame's motion;
- R – radius of a roller;
- φ – angle of a roller turn;
- l – half length of the band;
- μ – non-dimensional value of the mechanism resistance – the difference of the relative strains of the band's pieces;
- M_c – moment of resistance to motion;
- c – relative stiffness of the band (equal to ES)
- E – modulus of elasticity;
- S – cross-section of the band.

The first equation of the system (30) characterizes the relative deformation of a piece $d\varepsilon_1$ by the difference of strain (ε_1 , ε_2 and x) corresponds to the frame motion with regard to the middle of a band.

An analogous equation for $d\varepsilon_2$ corresponds to the difference between the actual motion of the roller and the frame; then, x is included with opposite sign, because the length of the band's piece decreases.

The equations are constructed with an assumption that $dx > 0$, $d\varphi > 0$ (the frame goes from left to right). The given condition is receivable for an arbitrary system, and an additional calculation is required only for μ .

According to (30) $d\varepsilon_1 = d\varepsilon_2$ as $\varepsilon_1 - \varepsilon_2 = const$. Then:

$$\frac{dx - Rd\varphi(1 + \varepsilon_1 - \varepsilon_2)}{l + x} = \frac{Rd\varphi - dx}{l - x} \quad (31).$$

After the transformation it is obtained:

$$\begin{aligned} 2l dx &= [2Rl + R\mu(l - x)]d\varphi \\ d\varphi &= \frac{dx}{R \left[1 + \frac{\mu}{2} \left(1 - \frac{x}{l} \right) \right]} \end{aligned} \quad (32).$$

As $\mu \ll 1$, Equation (32) goes to linear form and decomposes in a power series; it neglects higher orders:

$$d\varphi = \left(1 - \frac{\mu}{2} + \frac{\mu x}{2l} \right) \frac{dx}{R} \quad (33).$$

If it is assumed that $x = x_0$; $\varphi = \varphi_0$, then, it is obtained (by integrating) $x_1 > x_0$:

$$\varphi - \varphi_0 = \frac{x_1 - x_0}{R} \left(1 - \frac{\mu}{2} \right) + \frac{\mu(x_1^2 - x_0^2)}{4Rl} \quad (34).$$

The turning, when exists alternating motion of the rigid frame from x_1 up to x_0 , ($dx < 0$ and $d\varphi < 0$) is studied

$$\left. \begin{aligned} d\varepsilon_1 &= \frac{-Rd\varphi + dx}{l + x} \\ d\varepsilon_2 &= \frac{-dx + Rd\varphi(1 + \varepsilon_2 - \varepsilon_1)}{l - x} \\ \varepsilon_2 - \varepsilon_1 &= \mu \end{aligned} \right\} \quad (35).$$

After analogous transformations there exists:

$$\varphi_0' - \varphi_1 = \frac{x_0 - x_1}{R} \left(1 - \frac{\mu}{2} \right) - \frac{\mu(x_0^2 - x_1^2)}{4Rl} \quad (36).$$

If Equations (34) and (36) are summed, it is found that the value of an angle of slipping of the roller in one movement's cycle of the frame is:

$$\Delta\varphi = \varphi'_1 - \varphi_0 = \frac{\mu}{2Rl}(x_1^2 - x_0^2) \quad (37),$$

$\Delta\varphi$ – value of the slipping angle of the roller;
 $x_1 - x_0 = a$ – amplitude of the swinging rollers;

$\frac{x_1 + x_0}{2} = b$ – coordinate of the swinging centre.

Finally,

$$\Delta\varphi = \frac{\mu ab}{Rl} \quad (38).$$

Equation (38) allows an estimation of the situation of rollers from the deformation of the band that is influenced by the resistance to the motion; it is possible to assert about the availability of rollers slipping in RTM, bound with the elastic deformation of free pieces of the band. Below, this kind of slipping is named springy slipping.

According to relation (38), the value of springy slipping directly depends on the resistance force, the amplitude of motion and the value of the swinging centre coordinate.

The maximum values of springy slipping will take place at unilateral swinging RTM with the maximum amplitude at $a \rightarrow l$, i.e., the rollers should not be transferred over limits l of the band's middle. Thus, the springy slipping will concentrate from cycle to cycle. During symmetrical swinging (moving) the springy slipping of the rollers is compensating: if $b = 0$, then $\Delta\varphi = 0$.

4 COMPENSATION OF SPRINGY SLIPPING IN RTM

Springy slipping between the elements of the RTM depends on the strain of free band's pieces; this strain is influenced by the forces of resistance to motion to a greater degree.

The value of springy slipping of the elements is determined by the following equation:

$$\Delta x = \frac{\mu_0 ab}{l_0} \quad (39)$$

Δx – value of springy slipping;
 μ_0 – non-dimensional value of the resistance force;
 a – motion amplitude of the mechanism;
 b – coordinate of the centre of motion;
 l_0 – half length of the band.

Consistent patterns of the change of errors from the strain of free pieces of the RTM band are considered. According to the positions of the unit 4 in this paper (Fig.4), the difference between the relative strains of the band's pieces depends on the non-dimensional resistance force of μ_0 .

$$\varepsilon_2 - \varepsilon_1 = \mu_0 = \frac{P}{ES} \quad (40)$$

P – resistance force to motion;

E – modulus of elasticity of material of the band;

Allowing a preliminary band tension, and also that the sum of the deformations of the branches of the band is equal to zero, it is possible to consider the following expressions:

$$\Delta\varepsilon_2 - \Delta\varepsilon_1 = \mu_0 \quad (41),$$

$$(l_0 + z)\Delta\varepsilon_2 + (l_0 - z)\Delta\varepsilon_1 = 0 \quad (42).$$

Then, on the basis of these relations it is possible to record the formulae reflecting the changes of the relative strains of the band's pieces with allowance for the preload

$$\Delta\varepsilon_1 = -\mu_0 \frac{l_0 + z}{2l_0}; \quad \Delta\varepsilon_2 = \mu_0 \frac{l_0 - z}{2l_0} \quad (43),$$

$$\varepsilon_1 = \varepsilon_0 - \mu_0 \frac{l_0 + z}{2l_0}; \quad \varepsilon_2 = \varepsilon_0 + \mu_0 \frac{l_0 - z}{2l_0} \quad (44).$$

The graphs of changes of ε_1 and ε_2 of z for the cycle of the mechanism movement can be plotted according to the relations (43) and (44) (Fig. 5). The values of the strain leaps during the transition moment from the moving rightwards to the moving leftwards at the point z_{max} are expressed by:

$$\Delta\varepsilon_1 = \mu_0 \frac{l_0 + z_{max}}{l_0}; \quad \Delta\varepsilon_2 = -\mu_0 \frac{l_0 - z_{max}}{l_0} \quad (45)$$

and vice versa, in the point z_{min} by:

$$\Delta\varepsilon_1 = \mu_0 \frac{l_0 + z_{min}}{l_0}; \quad \Delta\varepsilon_2 = -\mu_0 \frac{l_0 - z_{min}}{l_0} \quad (46).$$

So, knowing the length of the free piece of the band, one can define the error of the roller positioning band mechanism from springy slipping of the elements. During symmetrical swinging with respect to the centre of the band length the error will not have a tendency to accumulate, but will be compensated during the cycle of the movement. The maximum error with an accumulative effect (slipping)

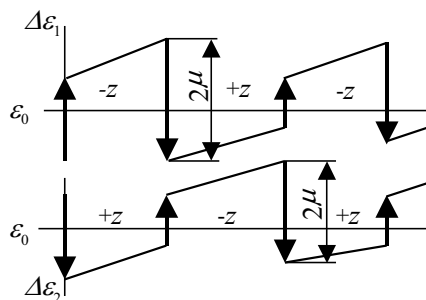

Fig. 5. Graphs of the strains' changes in the free band's pieces of RTM during forwarding and returning motion

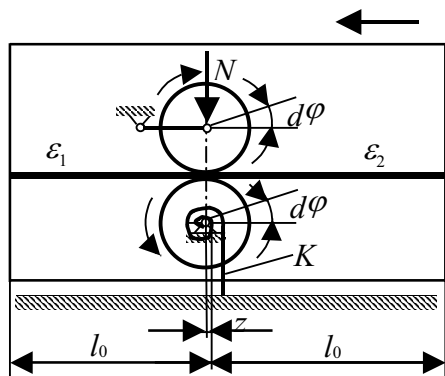

Fig. 6. Calculation scheme of the springy slipping compensator

will appear only during uni-directional motion of the mechanism with maximum amplitude at $a \rightarrow l_0$.

The most advisable is the compensation of springy slipping by a spring-compensator.

A simple model is explored in Fig. 6.

The spring-compensator K loads the axle of the measurement or the auxiliary roller so that the tension of the roller of the longer band's piece was greater, i.e., $\varepsilon_1 > \varepsilon_2$ when $x > 0$. Or else: if $\varphi = 0$ when $x = 0$, and the frame is stable, then the difference in the tension is proportional to φ (with a coefficient A). The spring tries to return the roller back to the position $\varphi = 0$, wherever it is skewed. The necessary springing force is calculated when the frame is moving leftwards:

$$\left. \begin{aligned} d\varepsilon_1 &= \frac{dx - Rd\varphi(1 + \varepsilon_1 - \varepsilon_2)}{l_0 + x} \\ d\varepsilon_2 &= \frac{Rd\varphi - dx}{l_0 - x} \\ \varepsilon_1 - \varepsilon_2 &= \mu_0 + A\varphi \end{aligned} \right\} \quad (47)$$

$\mu_0 = \frac{M_c}{h_c} = \frac{M_c}{REF}$ – nondimensional resistance of the mechanism, where

M_c – moment of motion resistance.

If M_1 stands for the moment caused by the spring that is turned by 1 rad, then

$$A = \frac{M_1}{REF} \quad (48)$$

It can be concluded that:

$$d\varepsilon_1 - d\varepsilon_2 = Ad\varphi \quad (49)$$

If appropriate equations are inserted, such an equation is derived:

$$dx = R \left[1 + \frac{1}{2}(\mu_0 + A\varphi) \left(1 - \frac{x}{l_0} \right) + \frac{A(l_0^2 - x^2)}{2Rl_0} \right] d\varphi \quad (50)$$

Taking into account that μ_0 and A are of the same order ($\leq 10^{-3}$) and $\mu_0 \ll 1, A \ll 1$, Equation (50) is as follows:

$$R \frac{d\varphi}{dx} = 1 - \frac{1}{2}(\mu_0 + A\varphi) \left(1 - \frac{x}{l_0} \right) - \frac{A(l_0^2 - x^2)}{2Rl_0} \quad (51)$$

If Equation (51) is reduced to the standard form of a linear differential equation the following expression is obtained:

$$\frac{d\varphi}{dx} + \frac{A}{2R} \left(1 - \frac{x}{l_0} \right) \varphi = \frac{1}{R} \left[1 - \frac{\mu_0}{2} \left(1 - \frac{x}{l_0} \right) - \frac{A(l_0^2 - x^2)}{2Rl_0} \right] \quad (52)$$

When symbols are used:

$$P_0 = \frac{A}{2R} \left(1 - \frac{x}{l_0} \right) \quad (53)$$

$$Q_0 = \frac{1}{R} \left[1 - \frac{\mu_0}{2} \left(1 - \frac{x}{l_0} \right) - \frac{A(l_0^2 - x^2)}{2Rl_0} \right] \quad (54)$$

then Equation (52) is rewritten as:

$$\frac{d\varphi}{dx} + P_0\varphi = Q_0 \quad (55)$$

The solution to (50), corresponding to the initial conditions $\varphi = \varphi_0$, when $x = x_0$, is:

$$\varphi = e^{-\int_{x_0}^x P_0 dx} \left[\varphi_0 + \int_{x_0}^x Q_0 e^{\int_{x_0}^x P_0 dx} dx \right] \quad (56)$$

After transformation and reduction, Equation (51), integrating from x_0 to x_1 , is:

$$\varphi_1 = \varphi_0 \left(1 - \int_{x_0}^{x_1} P_0 dx \right) + \int_{x_0}^{x_1} Q_0 dx - \int_{x_0}^{x_1} \left(\int_{x_0}^{x_1} Q_0 dx \right) P_0 dx \quad (57)$$

When the frame is moving rightwards, then:

$$\left. \begin{aligned} d\varepsilon_1 &= \frac{-Rd\varphi + dx}{l_0 + x} \\ d\varepsilon_2 &= \frac{-dx + Rd\varphi(1 + \varepsilon_2 - \varepsilon_1)}{l_0 + x} \\ \varepsilon_2 - \varepsilon_1 &= \mu_0 - A\varphi \end{aligned} \right\} \quad (58)$$

Similarly to the previous case the following relations are obtained:

$$\varphi'_0 = \varphi_1 \left(1 - \int_{x_0}^{x_1} P_1 dx \right) + \int_{x_0}^{x_1} Q_1 dx - \int_{x_0}^{x_1} \left(\int_{x_0}^{x_1} Q_1 dx \right) P_1 dx \quad (59)$$

$$P_1 = -\frac{A}{2R} \left(1 + \frac{x}{l_0} \right) \quad (60)$$

$$Q_1 = \frac{1}{R} \left[1 - \frac{\mu_0}{2} \left(1 + \frac{x}{l_0} \right) - \frac{A(l_0^2 - x^2)}{2Rl_0} \right] \quad (61)$$

After summing Equations (28) and (30), integrating and rejecting $\mu_0^2, A^2, \mu_0 A$ because of their low importance, it is found:

$$\varphi_0' + \varphi_1 = -\frac{A(\varphi_0 - \varphi_1)(x_1 - x_0)}{2R} + \frac{A(\varphi_0 - \varphi_1)(x_1^2 - x_0^2)}{4Rl_0} + \frac{\mu_0(x_1^2 - x_0^2)}{2Rl_0} + \frac{A}{4R^2}(x_1^2 - x_0^2)\frac{x_1 - x_0}{l_0} \quad (62)$$

Let $a = x_1 - x_0$ stand for the amplitude, the position of the middle point of swinging being $b = \frac{x_1 + x_0}{2}$. Then

$$ab = \frac{x_1^2 - x_0^2}{2} \quad (63),$$

$$\varphi_0 + \varphi_1 = \frac{x_0 + x_1}{R} = \frac{2b}{R}; \quad \varphi_1 - \varphi_0 = \frac{x_1 - x_0}{R} = \frac{a}{R} \quad (64).$$

Inserting Eqns. (63) and (64) into Eqn. (62), finally it is derived:

$$\varphi_0' - \varphi_0 = \frac{ab}{R} \left(\frac{\mu_0}{l_0} - \frac{A}{R} \right) \quad (65).$$

This is a turning after the movement from x_0 to x_1 and vice versa, but to make it zero, one needs $A = M_1 R / l_0$, where the moment M_1 , needed for turning by 1 rad, is found from the resistance moment M_c :

$$M_1 = M_c \frac{R}{l_0} \quad (66).$$

Thus, the accounting dependence (46) allows us to find the parameters of the compensating spring, that eliminates the springy slipping of one of the RTM rollers.

5 CONCLUSIONS

The presence of a springy link in the structure of the RTM imposes limitations on the kinematics of the RTM. The influence of the deviation from the rollers' diameter to the kinematic precision of the RTM shows up while changing the roller's wrapping angle with the band. Theoretical research proved:

1. There exists kinematically irreversible geometrical slipping of the elements of PRBM. Its magnitude is influenced by the thickness of the flexible band.
2. Geometrical slipping between the elements of the PRBM can be compensated, if an additional flexible band, wrapping the rollers from the opposite side, complements the design.
3. In spite of the design, technological and operational errors of the RTM, the main influence on the kinematic precision is made by geometrical and springy slipping of the elements because of the imperfection of the structural links.
4. A compensator can eliminate the springy slipping. The springing force is calculated according to the analytical relation that was derived.

6 REFERENCES

- [1] Wilkes, D., F. Rolamite (1967) A new mechanical design concept. Research report SC-RR-67-656 A, Sandia Laboratories, December, 1967, 223p.
- [2] Wilkes, D., F. Rolamite (1968) A new mechanism. *Mechanical Engineering*. April, v.90, No 4, 11-29.
- [3] Cadman, R., V. Rolamite (1969) Geometry and force analysis. *Journal of Engineering for Industry. Trans. ASME, Series B*, Feb., v.91, No 1, 185-191.
- [4] Percival, C.M., F.R. Norwood (1969) A theoretical and experimental investigation of the dynamic response of Rolamite. *Trans. ASME, Ser.B*, v.91, No 1, 235-239.
- [5] SU invention No 1516348. Int. Cl.⁴ B25J 15/02; B25J 11/00.
- [6] SU invention No 1566851. Int. Cl.⁴ F16H 19/06; H02N 2/00.

Authors Address: Prof.Dr. Ričardas Viktoras Ulozas
Šiauliai University
Vilniaus 141
Šiauliai, LT-5400
Lithuania
ulozas@tf.su.lt

Prejeto:
Received: 30.6.2003

Sprejeto:
Accepted: 18.6.2004

Odrpto za diskusijo: 1 leto
Open for discussion: 1 year