

Performance Analysis of the Reheat-Stop-Valve Mechanism under Dimensional Tolerance, Misalignment and Thermal Impact

Xu Dong^{1,*} - Jin Ye¹

¹ Shanghai Jiao Tong University, School of Mechanical Engineering, China

The reheat-stop-valve (RHSV) mechanism is a principal component in a steam turbine unit which controls the running state. Mechanical jamming and incompleteness often occur during closing the mechanism. This paper proposes a method to quantitatively investigate the cumulative effect of dimensional tolerance, misalignment and thermal impact on the dynamic performance with shaft and bearing pairs in a RHSV mechanism. Finite element method is employed to study the effect of thermal impact on the clearance of the shaft and bearing pairs. Then, we calculate the clearance of the shaft and bearing pairs considering thermal impact and dimensional tolerance. Based on the non-linear clearance and misalignment, a model named compensation cone is developed to establish the multi-support mechanism of the shaft and bearings system. The method is demonstrated by applying to the RHSV mechanism in a supercritical steam turbine unit. The results indicate that the combined effect of dimensional tolerance, misalignment and thermal impact exerts great effect on the performance of mechanism.

© 2009 Journal of Mechanical Engineering. All rights reserved.

Keywords: dimensional tolerance, misalignment, thermal impact, clearance, performance

0 INTRODUCTION

Valve and actuating mechanisms are principal constituents in a steam turbine unit which controls the running state. With the improvement of unit capacity of the steam turbine units, extra high temperature and pressure steam are required, which further demands safer and more reliable valves and actuating mechanisms.

At the same time, the possibility of mechanical jamming and poor dynamic properties of valves and actuating mechanisms increases rapidly with the improvement of steam parameters in engineering practice. Mechanical jamming is one of the fatal failure modes which lead to the loss of mechanism function thoroughly. A failure of control system, unreasonable structure design, poor tolerance design and thermal deformation are possible factors resulting in mechanical jamming or poor dynamic properties in a mechanism. Failure due to the former two factors can be easily discovered and solved, while it is difficult to discover failure due to poor tolerance design, [1] and [2] and thermal deformation.

Tolerances define the allowable variations in the geometry and positioning of parts in a mechanical assembly, so as to assure its proper

functionality [3]. However, the development of tolerance for function is not optimistic, and tolerance allocation still depends on experiences and experimental results in practice. Many researchers proposed linear or non-linear model to study in depth the relationship between part tolerance and assembly tolerance through tolerance analysis, [4] to [7]. Therefore, there still exists a gap to ensure the function and performance of mechanism through tolerance allocation and error control.

Pezzuti [8], Li [9] and [10], Simon [11], and Flores [12] studied the effects of machining errors, misalignment and deformation on various performances of mechanisms, such as efficiency, strength, transmission errors and dynamics. Their research showed that misalignment exerted great effect on the performance of the mechanism. Monmousseau [13] studied the influence of misalignment of a journal bearing, the results showed that the misalignment induced large changes in the bearing characteristics. Eberlinc [14] studied the blade deformation during operation on the fan's aerodynamic characteristic. Thus improved form of the blade could be determined. Venanzi [15], Zhu [16] and Castelli [17] investigated the influence of the clearance on mechanism accuracy. They denoted the clearance

*Corr. Author's Address: Shanghai Jiao Tong University, School of Mechanical and Power Engineering, Dong Chuan Road 800, Shanghai, China, jdongxu@yahoo.com.cn

as a two dimensional virtual link. Kim [18] proposed a method to predict the effect of the assembly tolerances and thermal deformation on dynamic characteristics. He concluded that both the performance and reliability of products are strongly influenced by temperature. Chen [19] analyzed mechanical jamming of synchronous gears in the deployment mechanism of a large satellite antenna under the combined effects of machining errors, assembly errors and space temperature. Istvan [20] studied the contact problem for both small and large displacements and deformation. Roberto [21] investigated the shaft bow influence on the rotor-stator contact dynamics. Saruhan [22] employed a genetic algorithm to predict the dynamic behavior of the rotor system. However, the work on the shaft and bearings system under combined effects of the above influencing factors is deficient.

This paper will present a method to investigate the effects of dimensional tolerance, misalignment and thermal impact on the performance of shaft and bearings pairs in the

RHSV mechanism of a supercritical steam turbine unit.

1 PROBLEM DESCRIPTION AND PRELIMINARY ANALYSIS

The RHSV mechanism is a principal constituent in a steam turbine unit which controls the running state. In addition, emergency shutdown of the steam turbine unit is also realized via operating the valve. Once severe failure appears in the steam turbine in full load condition and the RHSV mechanism fails to function, a bad accident will inevitably occur. A typical structure of the RHSV mechanism is shown in Figure 1 with unit mm, which is widely used in high-powered steam turbine units of power plants, especially in nuclear plants. The dimensions at the mating surfaces for each shaft and bearing pair are given in drawings:

- $\phi 123.86 \pm 0.01 / \phi 123.39 \pm 0.01$,
- $\phi 127.2 \pm 0.01 / \phi 126.57 \pm 0.01$,
- $\phi 127.2 \pm 0.01 / \phi 126.57 \pm 0.01$ and
- $\phi 133.73 \pm 0.01 / \phi 133.1 \pm 0.01$.

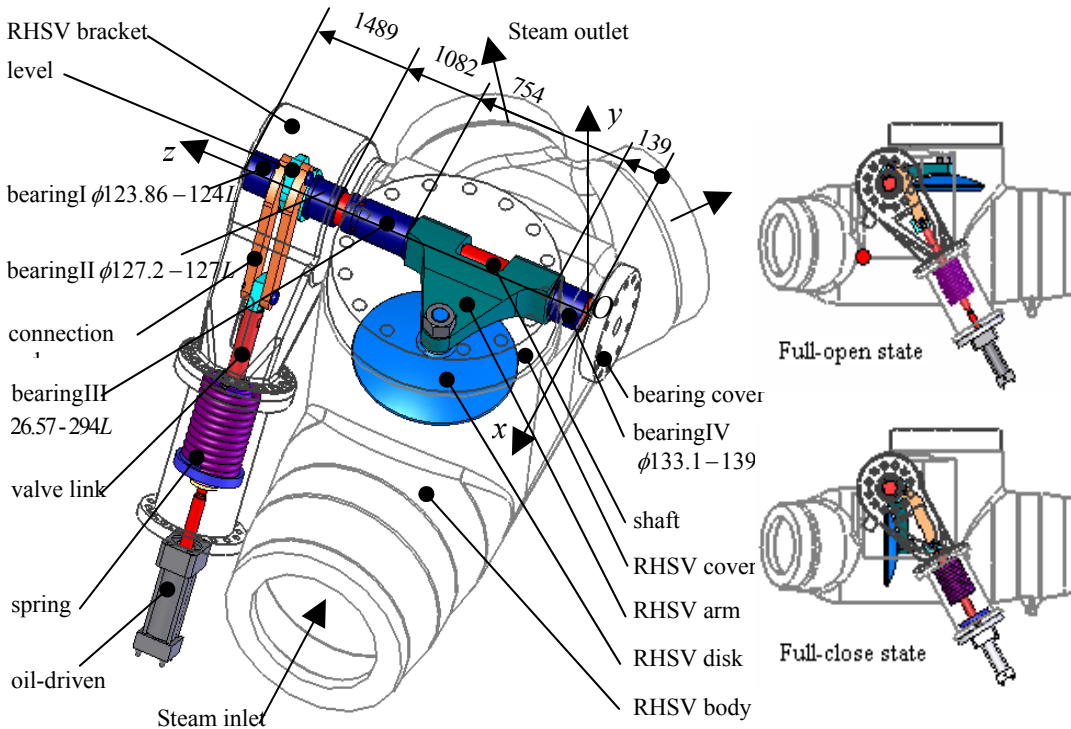

Fig. 1. Three dimensional structure of the RHSV mechanism

1.1 Description of Mechanical Jamming and Incompetence Phenomenon

Mechanical jamming and incompetence occur at full open state in some RHSV mechanisms of supercritical steam turbine units when they bring into service. These mechanisms work in high temperature and high pressure environment at about six hundred degrees Centigrade, it is called hot condition. Mechanical jamming and incompetence never appeared if there was no high temperature steam inside the RHSV mechanism, it is called cold condition. The shutdown time is about 0.2 s in cold condition which is smaller than the critical value 0.3 s according to the design requirement. Otherwise, the possibility of mechanical jamming in subcritical steam turbine units which work in a lower temperature environment is much smaller.

1.2 Preliminary Analysis

1.2.1 Dynamic analysis for RHSV mechanism with ideal dimensions and configuration

The RHSV mechanism is simplified as an offset endplay device as shown in Figure 2 if the shaft rotor and the pins are regarded as rotating pairs. Where M_{f1} is the gross friction moment in the revolute joint O. M_{f2} and M_{f3} are the friction moments at the revolute joints A and B, respectively. f_E is the frictional force at the translational joint E. R_{ox} , R_{oy} , R_E are the support forces. F_2 is the gravity at the joint O. M_d is the driving moment in joint O considering gravitation and spring forces. $l_1 = 89$ mm; $l_2 = 790.35$ mm; $OA = 127$ mm; $AB = 489$ mm. F_1 is the resultant spring force of the two springs, which could be formulated as the following equation with unit N.

$$F_1 = 2.23 \cdot 10^4 - 0.723 \cdot 10^4 \cdot \sin(\varphi - \frac{2\pi}{3}), \quad (1)$$

where, φ satisfies $\frac{5\pi}{12} \leq \varphi \leq \frac{11\pi}{12}$.

The results of a dynamic analysis when closing the RHSV mechanism are illustrated in Figure 3. where spring moment and gravity are the driving moments generated by the springs and the gravity around the joint O, respectively. Friction moment is the total friction moment in the RHSV mechanism, which equals the sum of M_{f1} , M_{f2} , M_{f3} and $f_E l_1$. The mechanism shuts down in less than 0.2 seconds, which is smaller than the critical

closing time 0.3 seconds by the designers. In power plants, down time is about 0.2 seconds in cold condition. This means that the numerical method is effective for dynamic analysis of RHSV mechanism. However, the friction moment M_{f1} in hot condition may be greatly different from the one in cold condition, which should be calculated in detail.

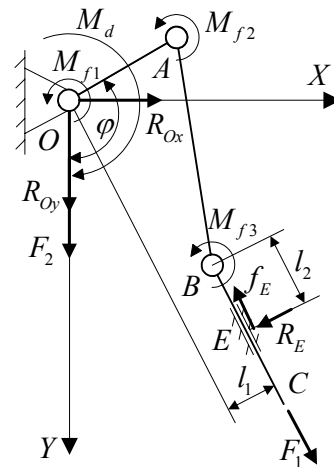
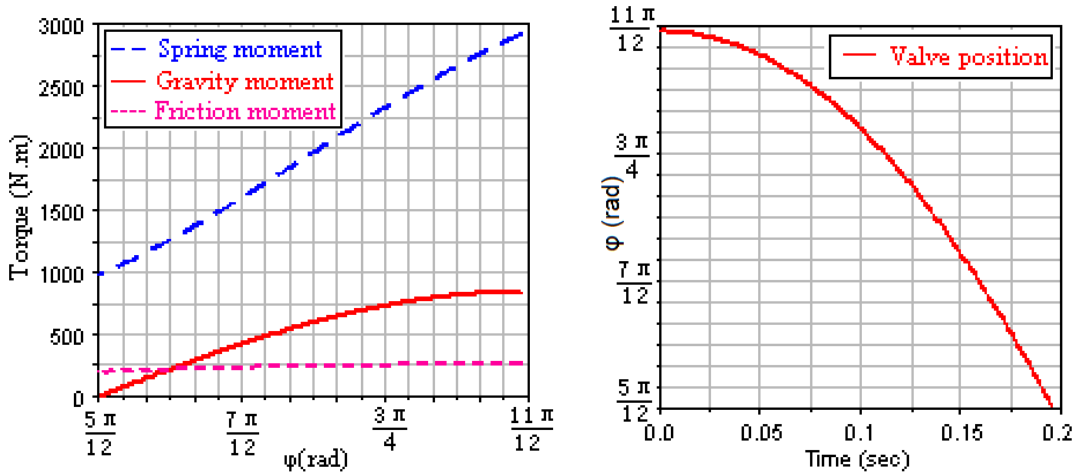

Fig. 2. Force diagram of the reheat-stop-valve mechanism in work environment

1.2.2 Preliminary analysis of mechanical jamming

The mechanical jamming phenomenon and dynamic analysis have provided large quantities of valued information to analyze the factors of mechanical jamming. Firstly, the perfect dynamic performance in cold condition and dynamic analysis show that the structure of RHSV mechanism is reliable and reasonable. Secondly, thermal impact is the immediate cause of the emergence of mechanical jamming in hot condition. Thermal impact changes the shape and configuration of parts and further reduces the clearance among the shaft and the four bearings. Thermal impact exerts little effect on the parts far away from the high temperature steam such as level, connecting rod, valve link in the endplay device. Thirdly, machining errors and the misalignment affect the clearance as well.

Moreover, the uncertainty of machining errors and misalignment explain why mechanical jamming and incompetence emerges in only partial mechanisms.



(a) Driving and friction moment when closing valve (b) Dynamic performance when closing valve

Fig. 3. Dynamic analysis results when closing the valve considering no extra force

2 CLEARANCE CALCULATION UNDER THE EFFECTS OF DIMENSIONAL DEVIATION AND THERMAL IMPACT

2.1 Calculation of Thermal Impact on Clearance

In the RHSV mechanism shown in Fig. 1, the inner side of the RHSV body is full of high temperature steam, about six hundred degree Centigrade, and the outer side of RHSV body is fresh air. Finite element method has been employed to quantitatively evaluate the temperature, stress and strain fields of the mechanism. The expansion increment is larger in shaft than the bearings, which reduce the clearance. The clearance shrinkage w between each shaft and bearing pair is the function of the mating point. For any mating point (x,y,z) , the clearance shrinkage w equals to $\sqrt{u^2+v^2}$ with unit mm shown in Fig. 4. Where, u and v are parallel to x and y axes shown in Fig. 1, respectively.

The results indicate that thermal impact exerts great effect on clearance among shaft and bearing pairs, and the clearance shrinkage is non-linear and non-uniform along the axial direction. Furthermore, the effect of thermal impact attenuates quickly in the zones far away from the high temperature steam. As a result, thermal impact exerts much more effect on bearingIII and bearingIV than bearingI and bearingII. Besides, the parts such as level, connecting rod and valve

link are surrounded by ambient temperature air, so the thermal impact could be neglected.

2.2 Clearance Calculation under Dimensional Deviation and Thermal Impact

In the classical model with ideal joints, clearance is idealized as the difference of the diameters of the ideal hole and pin. In the RHSV mechanism, the fitting surfaces of the shaft and bearing pairs have deviated from the ideal position due to machining errors and thermal impact. Thus, the clearance width is distinct for the different matching point pair. Dimensional deviation changes the position of mating features. Thermal deformation alters the size and configuration of the parts. The thermal deformation is non-linear along the shaft axis based on the data in Fig. 4. Therefore, the actual radial clearance also has the non-linear characteristic for mating point pair along the shaft axis. Here, non-linear and non-uniform clearance means that the clearance is not constant along the axis direction or radial direction, but it could not be expressed in a linear function. The clearance may be different for each mating point pair.

In the RHSV mechanism, the nominal clearance all equals to 0.63 mm between shaft and bearingII, bearingIII or bearingIV, and 0.47 mm in bushingI. Here, the nominal clearance is the value that the bearing diameter subtracts the shaft diameter with equivalent upper and lower

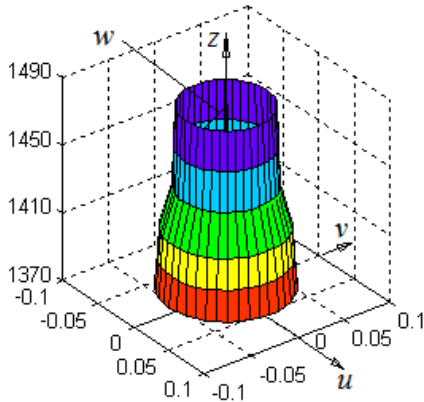

(a) Clearance shrinkage in shaft and bearing I pair

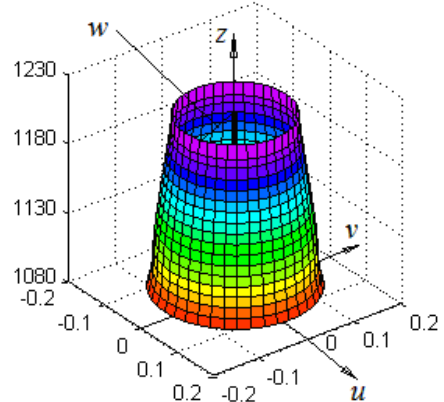

(b) Clearance shrinkage in shaft and bearing II pair

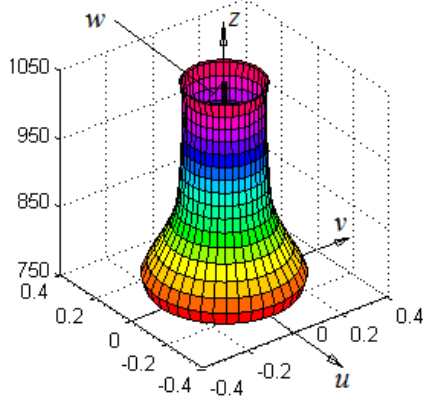

(c) Clearance shrinkage in shaft and bearing III pair

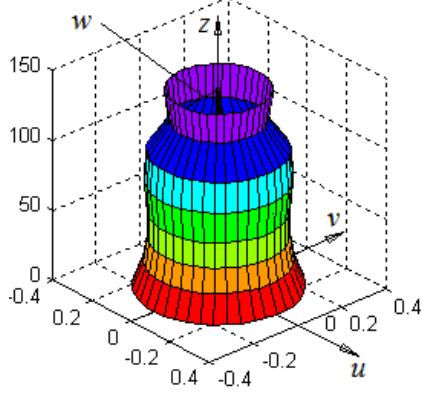

(d) Clearance shrinkage in shaft and bearing IV pair

Fig. 4. Clearance shrinkage in shaft and the bearing pairs caused by thermal impact

limits in blue drawings. The dimensional tolerance zones of the shaft diameter and bearing holes are within the interval $[-0.01, 0.01]$.

Let the shaft be in maximum size, and bearings be in minimum sizes. Then for each mating point (x,y,z) considering thermal impact, the minimum radial clearance C_{min} could be formulated as $C_{min} = \sqrt{u^2 + v^2}$ with unit mm shown in Figure 5. Where, u and v are the projection of the radial clearance along x and y axes, respectively.

Let T the sum of shaft tolerance and bearing tolerance size. Then, the maximum radial clearance is half of T , that is 0.02 mm, larger than the minimum radial clearance.

The data in Fig. 5 show that the radial clearance under the cumulative effects of dimensional deviation and thermal impact is always positive in all the shaft and bearing pairs, if the axes of shaft and the bearings are assumed to be coaxial. In fact, the concentricity

requirement can not be assured due to machining errors and assembly errors.

3 THEORETICAL METHOD FOR STATIC AND DYNAMIC ANALYSIS

Previous work [8] and [15] has illuminated that mechanics analysis is effective to quantitatively investigate the effects of the clearance and misalignment on the performance of mechanism. Thus, the mapping between dimensional tolerance, misalignment, thermal impact and performance of mechanism could be established through static analysis and clearance calculation.

3.1 Mechanics Modeling Under the Cumulative Effects of Multiple Factors

Mechanics modeling is the primary task for mechanical analysis. But mechanics modeling is not an easy job in mechanism with uniform

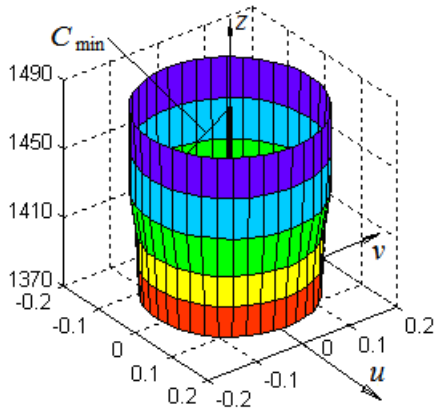

(a) Radial clearance for pair of shaft and bearing I

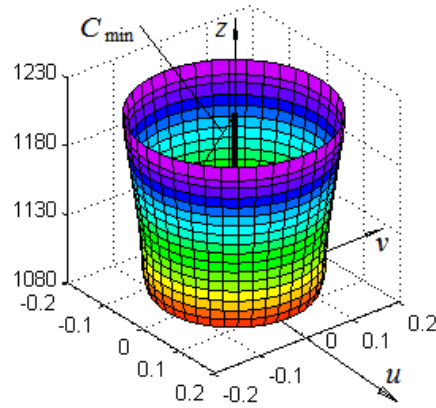

(b) Radial clearance for pair of shaft and bearing II

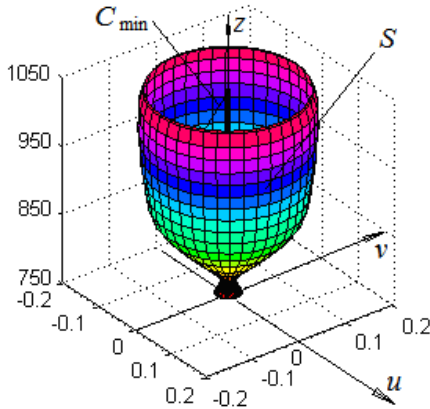

(c) Radial clearance for pair of shaft and bearing III

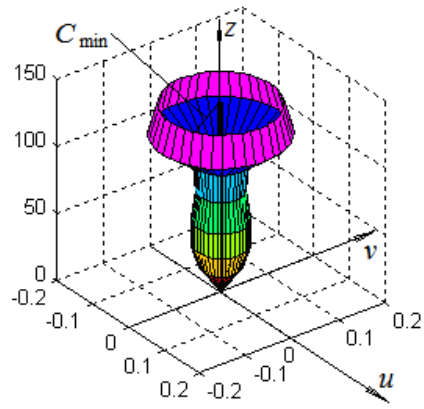

(d) Radial clearance for pair of shaft and bearing IV

Fig. 5. Minimum radial clearances considering thermal impact between shaft and the bearings

clearance along axial and circumferential direction [8]. It is much more complicated for non-linear and non-uniform clearance along axial and circumferential direction, which has not attracted much attention.

The dimensional deviation and thermal impact changes the uniform clearance into non-linear and non-uniform clearance along axial direction. The misalignment alters the radial clearance into non-linear and non-uniform clearance along circumferential direction. Non-linear and non-uniform clearance brings trouble in deciding contact zones or contact points, which is significant in mechanics modeling.

A new method is presented for performance analysis of the RHSV mechanism with non-linear and non-uniform clearance based on the compensation cone. The process of quantitative performance analysis is illustrated in

Fig. 6. Dimensional errors of pair elements, thermal deformation and misalignment of bearings are the major factors to cause variation of mechanism performance.

3.1.1 Compensation cone for non-clearance and non-uniform clearance

The definition of the compensation cone is clarified with the shaft and bearing III pair at the state of minimum radial clearance, shown in Fig. 5(c). The process is given in the following steps:

Step one, let the axes of the mating features of the shaft and bearing be coaxial. The surface S denotes the actual radial clearance between the mating features, shown in Fig. 7.

Step two, the surface S and its two end planes S_u and S_l form a closed space V . Let S_{min} be the cross-section inside V normal to the datum axis with minimum inscribed circle.

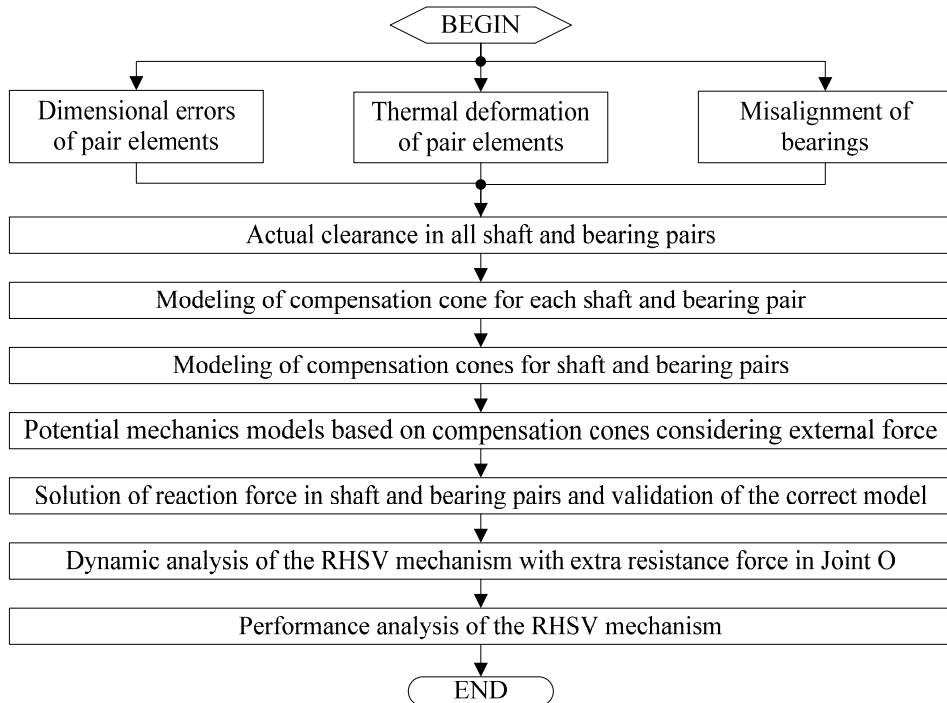

Fig. 6. Performance analysis of the RHSV mechanism with compensation cone

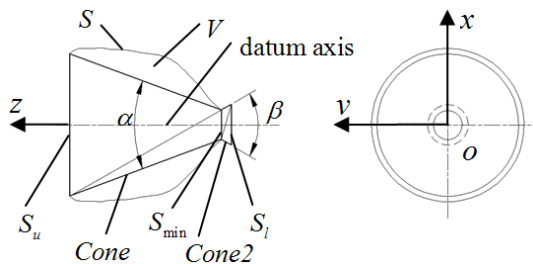

Fig. 7. Modeling of compensation cone with minimum radial clearance in shaft and bearing III pair

Step three, S_{min} may be one of the end plane or mid plane between the end planes. If it is the end plane, there only exists one maximum inscribed cone of V , and the cone is named as the compensation cone. If S_{min} is the mid plane between the end planes, there exist two maximum inscribed cones. Abandon the cone with bigger cone angle. Then the reserving cone is named as the compensation cone.

For the shaft and bearing III pair, S_{min} is the mid plane, and *Cone1* and *Cone2* are the maximum inscribed cones, shown in Fig. 6. In the case, $\alpha < \beta$. Then, *Cone2* is the compensation cone.

If the misalignment of the bearing is also considered, the compensation cone could be modeled in Fig. 8. The compensation cone could be represented with eight parameters: $x_1, y_1, x_2, y_2, z_1, z_2, \alpha, R$. The former four variables define the misalignment deviating from the datum axis of the actual bearing axis. The other four variables are related to the initial clearance, dimensional errors and thermal deformation. Consequently, the compensation cone with eight parameters can describe the actual clearance and the position of each shaft and bearing pair.

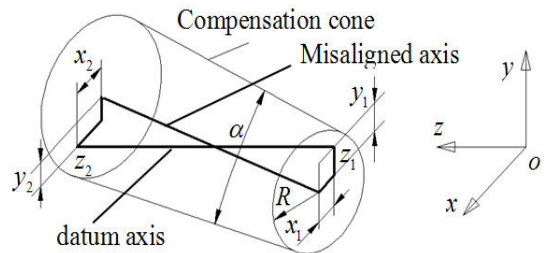

Fig. 8. Schematic compensation cone considering another factor misalignment

The compensation cone has two functions. The main function is used to assist in constructing the multi-support mechanism of the shaft and bearings pairs. The other function is to find the maximum correction ability of the clearance between the shaft and bearing for misalignment.

3.1.2 Modeling of shaft and bearing pairs based on compensation cone

Modeling the multi-support mechanism shaft and bearing pairs includes two procedures: construction of compensation cones and supports analysis.

Compensation cones are used to substitute the non-linear and non-uniform clearance in modeling. The axis of the shaft should be located in the internal spaces of the compensation cones. The axes of the bearings deviate from the ideal position in any radial direction. Thus, two orthogonal planes are employed for the three dimensional misalignment. The primary plane passes through the vector of external force and datum axis, and the other plane is orthogonal to the prior plane through the datum axis. The compensation cones of the shaft and bearing pairs in RHSV mechanism for given dimensional deviation and misalignment are shown in Fig. 9.

The shaft is simplified as a spatial freely

supported beam. The construction of multi-support mechanism is greatly influenced by the supports. The procedure of the support analysis of Fig. 9(b) is discussed in detail based on the compensation cones.

The actual axis of shaft passes through compensation cone III, and it must interact with the line EF. Extension lines of DE and DF both interact with the line FH. The included angle between AD and DE is a little bigger than the one between AD and DF. Then, we can conclude that E is another support. Similarly, H is a support as well. For L and N, it difficult to judge if they are supports.

Consequently, for the compensation cones and external force shown in Fig. 9(b), there are three potential models shown in Figs. 10(a to c). The actual model needs to be determined by detailed calculations.

3.2 Static Analysis for the Multi-support Mechanism

The task for static analysis is to quantitatively obtain the reaction forces of the supports, and to confirm the validation of mechanics model. The potential mechanics models of RHSV mechanism shown in Figs. 10(a to c) are all statically indeterminate problems.

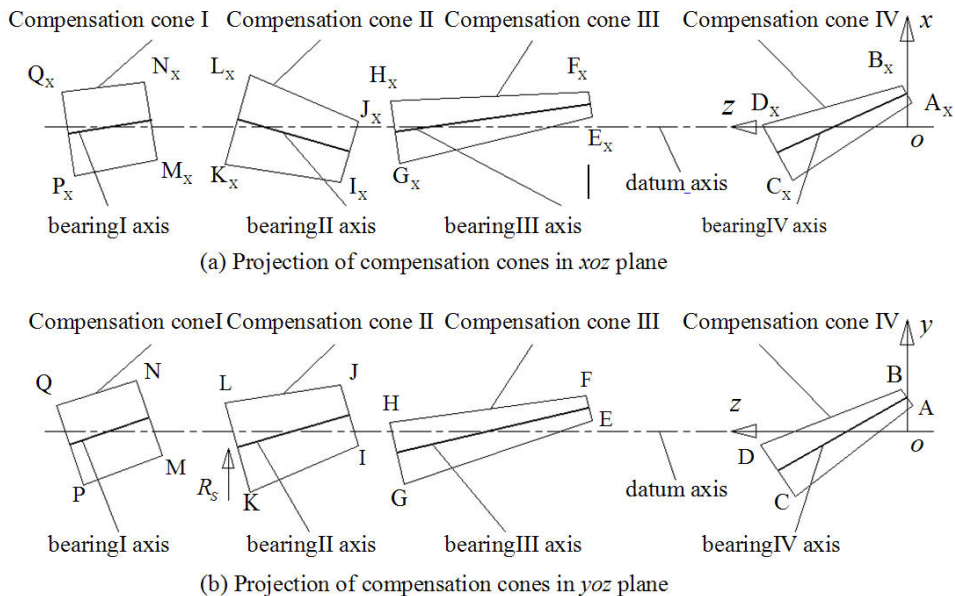

Fig. 9. Compensation cones in RHSV mechanism

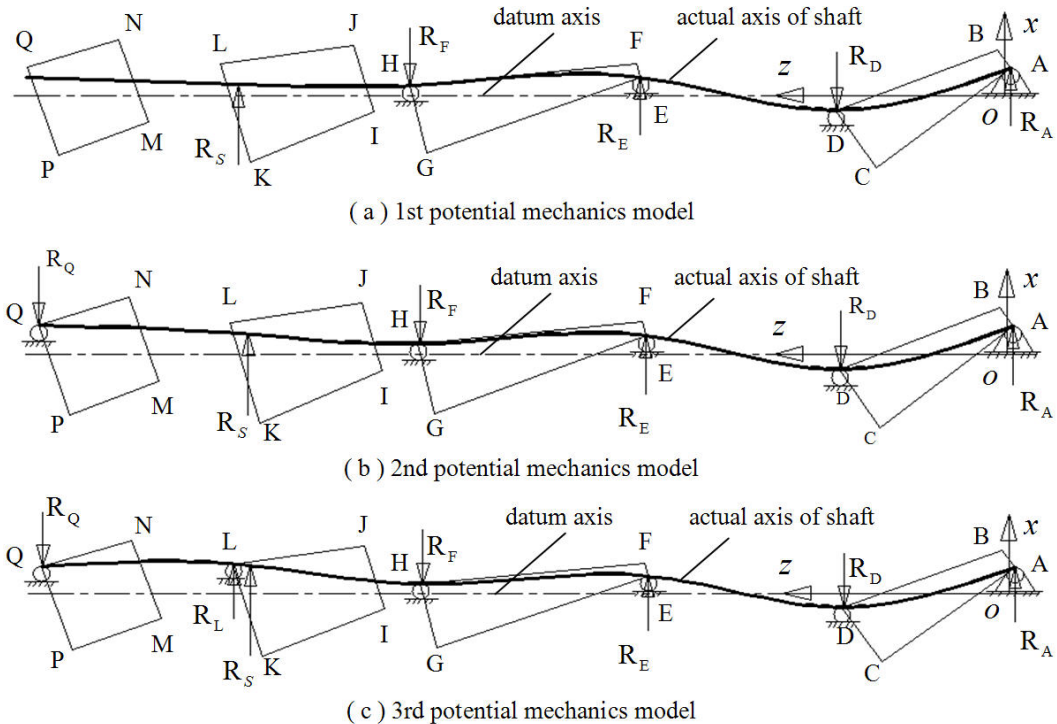

Fig. 10. Potential mechanics models based on compensation cones

As for the solution of the indeterminate problems, a lot of methods have already been proposed, such as finite difference method, generalized staircase function, finite element analysis and the superposition method. Here, the superposition method is adopted to obtain the reaction forces. How to solve such problems will be neglected here.

The results are employed to confirm the validation of the mechanics models. The vectors of the reactions should be orthogonal to the corresponding bearing axes, and point from the contact points to crossing points with the bearing axes. If the value of reaction is negative, then the support is not a valid one, and the corresponding mechanics model is invalid. Reaction forces of valid mechanics model will be applied for further dynamic analysis or mechanical jamming analysis.

3.3 Mechanical Jamming Analysis or Dynamic Analysis based on Static Analysis

The valid mechanics model and the reaction forces of supports can be obtained

through static analysis. Extra friction moment due to the reactions arise when we close the RHSV mechanism of the steam turbine. The extra resistance moment usually exerts great effect on the performance of the mechanism because small geometry deformation of parts may produce great reaction forces.

If the sum of the maximum static friction moments induced by the reactions in the whole mechanism exceeds the drive moment in the initial condition, mechanical jamming occurs when we close the RHSV mechanism. Otherwise, dynamic analysis needs to be applied to investigate the kinematic and dynamic performance.

4 EFFECTS OF DIMENSIONAL TOLERANCE, MISALIGNMENT AND THERMAL IMPACT ON PERFORMANCE OF MECHANISM

4.1 Effect of Misalignment on Performance of Mechanism

The effect of misalignment on the performance of a mechanism is evaluated by

fixing the effects of dimensions and the thermal impact. All dimensions are assumed in the maximum material condition. The thermal deformation in a steady state in hot condition is used in calculation.

The misalignment is divided into two types: misalignment in orientation and misalignment in distance. Misalignment in orientation expresses the included angle between the misaligned axis and the datum axis. Offsetting distance is applied to denote the distance between the misaligned axis and the datum axis. Misalignment in orientation is not convenient in engineering because of expression in angle. Then, the distance of declination is employed to express misalignment in orientation, which equals the projected distance between the misaligned axis and the datum axis on the end plane of the compensation cone. Thus, the distance of declination could be calculated with the model in Fig. 11.

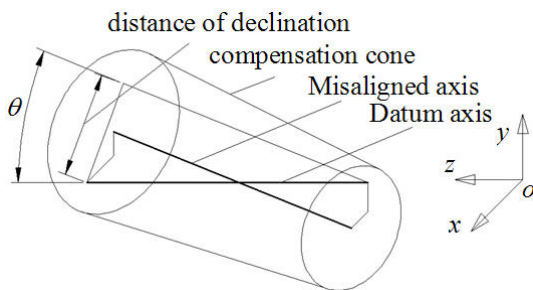

Fig. 11. Diagrammatic sketch of declination of distance

4.1.1 Effect of misalignment in orientation

Two typical sets of data are adopted to evaluate the effect of misalignment in orientation on the performance of RHSV mechanism.

The first case assumes that the axes of bearingI, bearingII and bearingIII are all in limited declination angles in the primary plane, and no deviation on the orthogonal plane as shown in Fig. 9. The relationship between extra friction moment and distance of declination in bearingIV is denoted by the curve C1 shown in Fig. 12. The distance of declination is assumed to be positive when point A is above the z axis.

The second case assumes that the axes of bearingI, bearingII and bearingIII all coincide

with datum axis. The relationship between the extra friction moment and the distance declination of axis in bearingIV is shown in curve C2 in Fig. 12.

The friction moment values of L1, L2 and L3 correspond to three critical states, which could be calculated by the dynamic model in Fig. 2. At L1, the friction moment equals to 3460 Nm, is the critical value causing mechanical jamming. At L2, the friction moment equaling 2950 Nm, it could close the valve just critical. L3 corresponds to the friction moment 2050 Nm which could just close the valve within the critical time 0.3 s. Thus, the whole region is divided into four subregions by the lines L1, L2 and L3. If the friction moment is located within one of the four subregions, the dynamic performance of the mechanism could be evaluated. The subregion above L1 means mechanical jamming when closing the valve and the mechanism completely loses its ability. The subregion between L1 and L2 represents that mechanical jamming arises at a position between full-open and full-close state. The subregion between L3 and L4 represents that the mechanism can accomplish its operation, but the close time exceeds the critical time by the designer. The subregion under L4 indicates that the mechanism can completely satisfy the need of design requirement.

It is found that the distance of declination of bearingIV axis has a great effect on the friction moment. The friction moment becomes greater when the absolute value of the distance of declination increases. Besides, the friction moment nearly keeps constant when the distance of declination lies in the range near zero. This is because the clearance could correct the misalignment of the axes. Furthermore, when the misalignment varies in a small zone, the possibility of mechanical jamming is great and the possibility of satisfying specified dynamic performance is small.

By comparing the two curves C1 and C2, it is found that even if there is no misalignment in bearingI, bearingII and bearingIII, the misalignment variation of bearingIV axis greatly influences the performance of the mechanism.

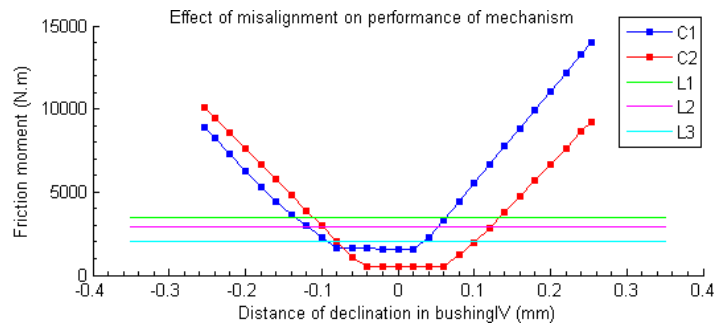

Fig. 12. Effect of misalignment in orientation on mechanical jamming

4.1.2 Effect of misalignment in distance

Maximum offsetting distance of the four bearings is used to predict the effect of misalignment in distance on mechanical jamming. The axes are in staggered arrangement in the primary plane to acquire the maximum contribution of misalignment in distance on the performance of mechanism. The valid mechanics model is illustrated in Fig. 13. The resultant friction moment equals 621.13 Nm, which is about 15 percent of the drive moment by static analysis. On the other hand, the friction moment equals 534 Nm without axes deviation of the four bearings. Therefore, the results indicate that the offsetting distance has little effect on the performance of the RHSV mechanism.

4.2 Effect of Dimensional Tolerance on Performance of Mechanism

The effect of dimensional tolerance on the performance is evaluated by fixing misalignment and thermal impact. The axes of bearingI, bearingII and bearingIII all coincide with datum axis.

Two typical sets of data are applied to evaluate the effect of dimensional tolerance on the performance of RHSV mechanism. The first case assumes that the dimensions are in a maximum material condition, and the second case assumes that all the dimensions are in nominal values. For the hole feature, the maximum material condition is corresponding to the minimum hole size. For the pin feature, the maximum material condition corresponds with the maximum pin size. In the RHSV mechanism, the span of the dimension variation of the above

two cases introduce 0.02 mm variation of radial clearance in the four bearings. The effect of dimensional tolerance on the performance of the mechanism is shown in Fig. 14. The curve C3 corresponds to the first case and C4 matches the second case.

Compared with the data of curves C3 and C4, it is found that the dimensional tolerance has a great effect on the performance of RHSV mechanism. The performance of the mechanism greatly fluctuates when the dimensions vary within the tolerance zones. Furthermore, the performance in C4 is a little better than the one in C3, and the extent that the friction moment nearly keeps constant is larger in C3 than in C4 because the radial clearance is larger in C3 than C4. It means that the enlargement clearance is an effective method to correct the misalignment. But enlargement clearance may result in gas leakage, which is prohibited in RHSV mechanism.

4.3 Effect of Thermal Impact on Performance of Mechanism

The analysis of the effects of dimensional tolerance and misalignment on the performance of the mechanism takes thermal impact into account. The cumulative effects of the above factors cause great fluctuation of performance of the mechanism.

If thermal impact is neglected, the clearance under the combined effect of dimensional tolerance, and misalignment is always positive by analyzing the data shown in Figs. 4 and 5. It is larger enough to correct the misalignment, so additional resistance moment will not appear in such case. The maximum resistance moment in the shaft and bearing pairs

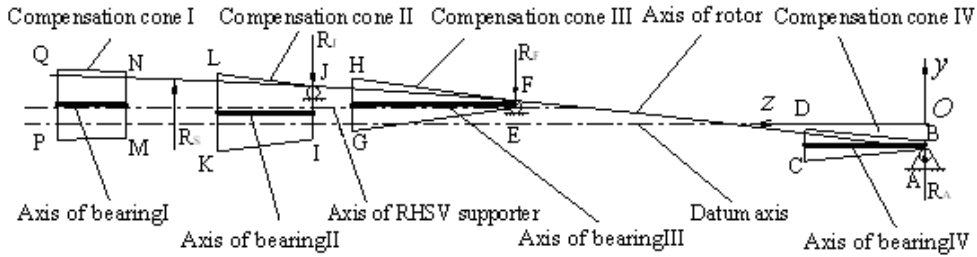

Fig. 13. Mechanics model under maximum offsetting distance

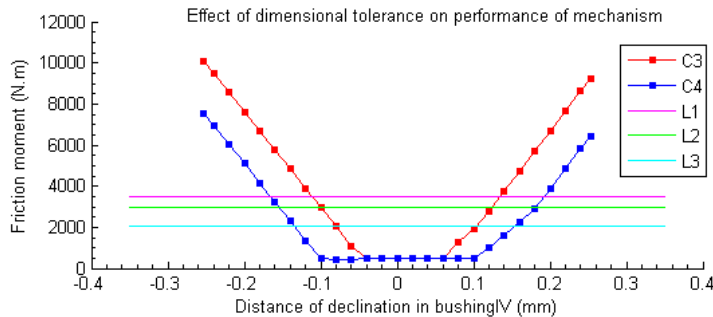

Fig. 14. Effect of dimensional tolerance on mechanical jamming

is about 534 Nm, and fourteen percent of drive moment. The dynamic performance can completely satisfy the need of the design requirement. Thereupon, mechanical jamming will not emerge in cold condition and less jamming in subcritical steam turbines.

4.4 Evaluation of Failure Possibility

We have analyzed the effects of misalignment of bearings, dimensional errors and thermal impact. Assume that the dimension errors and misalignment satisfy uniform distribution in the tolerance zone. The possibility of mechanical jamming, incompetence and delayed shutdown is about 30, 4 and 9%. The failure possibility when closing the RHSV mechanism is high. Some improvements have been made in the design and manufacturing process in engineering. The initial clearances are enlarged 0.02 mm in bearing III and bearing IV, respectively. And the concentricity errors of the four bearings should be controlled within ϕ 0.15 mm. Thus, the possibility of the above failure will be less than 5%.

5 CONCLUSION

This paper presents a method to quantitatively investigate the cumulative effects

under dimensional tolerance, misalignment and thermal impact on the performance of the RHSV mechanism with shaft and bearing pairs. A model named compensation cones is presented to establish the relationship between the influencing factors such as dimensional tolerance, misalignment and thermal impact and the performance of mechanism.

The results indicate that the performance of the mechanism greatly fluctuates when the uncertainty variables such as dimensions and misalignment vary in tolerance zone under the combined effects of dimensional tolerance, misalignment and thermal impact. Misalignment is divided into two classes: distance of declination and offsetting distance. The variation of distance of declination leads to a great fluctuation of the performance of the mechanism. On the other hand, the offsetting distance has little effect on mechanical jamming. The dimensional variation has a great effect on the performance of the mechanism. The possibility of mechanical jamming is much larger when part dimensions are in maximum material condition than in nominal values by fixing other influencing factors. The contribution of thermal impact on the performance of the mechanism is the greatest, but it keeps constant in steady state. Therefore, none of the influencing factors such as dimensional

tolerance, misalignment and thermal impact should be neglected in evaluating the performance of the mechanism when closing the RHSV valve.

6 REFERENCES

- [1] Weill, R., Clement, A. et. al. (1988) Tolerancing for function, *International institution for production engineering Research Annals* 37(2), p. 603-610.
- [2] Voelcker, H.B. (1995) Dimensional tolerancing today, tomorrow, and beyond, *ASME Papers presented at the 1995 ASME International Mechanical Engineering Congress & Exposition*, ASME Paper 95-WA/DE-8.
- [3] ASME (1994) Dimensioning and tolerancing principles. *ANSI Standard Y14.5.1M*. ASME.
- [4] Chase, K.W., Parkinson A.R. (1991) A survey of research in the application of tolerance analysis to the design of mechanical assemblies, *Research in Engineering Design* 3(1), p. 23-37.
- [5] Skowronski, V.J. (1998) Calculating derivatives in statistical tolerance analysis. *Computer-Aided Design* 30(5), p. 367-375.
- [6] Srikanth, K., Liou F.W., Balakrishnan S.N. (2001) Integrated approach for assembly tolerance analysis, *International Journal of Production Research* 39(7), p. 1517-1535.
- [7] Seo, H.S., Kwak B.M. (2002) Efficient statistical tolerance analysis for general distributions using three-point information, *International Journal of Production Research* 40(4), p. 931-944.
- [8] Pezzuti, E., Stefanelli R., Valentini P.P., Vital L. (2006) Computer-aided simulation and testing of spatial linkages with joint mechanical errors, *International journal for numerical methods in engineering* 65(11), p. 1735-1748.
- [9] Li, S.T. (2007) Effects of machining errors, assembly errors and tooth modifications on loading capacity, load-sharing ratio and transmission error of a pair of spur gears, *Mechanism and Machine Theory* 42(6), p. 698-726.
- [10] Li, S.T. (2007) Finite element analyses for contact strength and bending strength of a pair of spur gears with machining errors, assembly errors and tooth modifications, *Mechanism and Machine Theory* 42(1), p. 88-114.
- [11] Simon, V.V. (2006) Influence of tooth errors and shaft misalignments on loaded tooth contact in cylindrical worm gears, *Mechanism and Machine Theory* 41(6), p. 707-724.
- [12] Flores, P., Ambrosio J., Claro J.C.P., Lankarani H.M., Koshy C.S. (2006) A study on dynamics of mechanical systems including joints with clearance and lubrication, *Mechanism and Machine Theory* 41(3), p. 247-261.
- [13] Monmousseau, P., Fillon, M. (1999) Analysis of static and dynamic misaligned tilting-pad journal bearings, *Proceedings of the Institution of Mechanical Engineers, Part J: Journal of Engineering Tribology* 213(4), p. 253-261.
- [14] Eberlinc, M., Dular, M., Širok, B., Lapanja, B. (2008) Influence of Blade Deformation on Integral Characteristic of Axial Flow Fan, *Strojniški vestnik - Journal of Mechanical Engineering* vol. 54, no. 3, p. 159-169.
- [15] Venanzi, S., Parenti-Castelli, V. (2005) A New Technique for Clearance Influence Analysis in Spatial Mechanisms, *Journal of Mechanical Design* 127(3), p. 446-455.
- [16] Zhu J.M., Ting, K.L. (2000) Uncertainty analysis of planar and spatial robots with joint clearances. *Mechanism and Machine Theory* 35(9), p. 1239-1256.
- [17] Parenti-Castelli, V., Venanzi, S. (2005) Clearance influence analysis on mechanisms, *Mechanism and Machine Theory* 40(12), p. 1316-1329.
- [18] Kim, S.M., Lee, S.K, Lee K.J. (2002) Effect of bearing surroundings on the high-speed spindle-bearing compliance, *International Journal of Advanced Manufacturing Technology* 19(8), p. 551-557.
- [19] Chen, J.J., J.B. Zhang, B.Y. Duan, X.B. Wang (2005) Analysis of the seizure-preventing reliability of synchronous gears in the deployment mechanism of a large satellite antenna, *Journal of Xidian university* 32(3), p. 329-334.
- [20] Braut, S., Žigulić, R., Butković, M. (2008) Numerical and Experimental Analysis of a Shaft Bow Influence on a Rotor to Stator Contact Dynamics, *Strojniški vestnik -*

- Journal of Mechanical Engineering* vol. 54, no. 10, p. 693-706.
- [21] Paczelt, I., Baksa, A., Szabo, T. (2007) Product Design Using a Contact-Optimization Technique, *Strojniški vestnik - Journal of Mechanical Engineering* vol. 53, no. 7, p. 442-461.
- [22] Saruhan, H. (2007) Improving the Dynamic Characteristics of a Rotor System using an Evolutionary Algorithm, *Strojniški vestnik - Journal of Mechanical Engineering* vol. 53, no. 12, p. 898-912.