

## Matematični model za numerično simuliranje procesa vbrizgavanja v visokotlačnem vbrizgalnem sistemu ECD-U2

### A Mathematical Model for Numerical Simulation of the Fuel Injection Process in the ECD-U2 High Pressure Injection System

-----  
Breda Kegj

*V prispevku je predstavljen matematični model za numerično simuliranje procesa vbrizgavanja v elektronsko krmiljenem visokotlačnem vbrizgalnem sistemu ECD-U2 za dizelske motorje tovornih vozil. Matematični model temelji na predpostavki, da je tlak vbrizgavanja na izbranem delovnem režimu nespremenljiv. Glede na to je pozornost posvečena predvsem procesom, ki potekajo v vbrizgalni šobi. Obravnavane so različne izvedbe vbrizgalne šobe. Tako se lahko v modelu izbira med dvema različnima tipoma solenoidnih ventilov kakor tudi med uporabo dušilne ploščice ali hidravličnega ventila. Vplivi različnih elementov na karakteristike procesa vbrizgavanja so na podlagi numeričnih rezultatov na kratko analizirani.*

© 1999 Strojniški vestnik. Vse pravice pridržane.

**(Ključne besede: motorji dieselski, vbrizgavanje goriva, simuliranje numerično, karakteristike vbrizgavanja)**

*In this paper a mathematical model for numerical simulation of the fuel injection process in the electronically controlled high pressure ECD-U2 fuel injection system for a Diesel truck engine is presented. The proposed mathematical model is based on the assumption that the injection pressure of a selected engine operating regime is kept constant. Keeping this in mind, attention is focused on the processes in the injector. Several configurations of the injector are considered. Consequently, it is possible to choose between two different types of solenoid valves, as well as between the return and the boot valve. The influence of different parameters on the injection characteristics is discussed briefly using the obtained numerical results.*

© 1999 Journal of Mechanical Engineering. All rights reserved.

**(Keywords: Diesel engine, injection process, numerical simulations, injection characteristics)**

#### 0 UVOD

Želja po hkratnem zmanjšanju škodljive emisije izpušnih plinov, hrupa, specifične porabe goriva in povečanju zmogljivosti dizelskega motorja tovornih vozil terja poleg visokotlačnega vbrizgavanja tudi boljše krmiljenje sistema za vbrizgavanje goriva. Za uresničitev omenjenih zahtev so dandanes razviti številni vbrizgalni sistemi za dizelske motorje tovornih vozil. Eden izmed uspešnejših je visokotlačni vbrizgalni sistem ECD-U2 proizvajalca Nippondenso, ki se od leta 1995 vgrajuje v 8-litrski motorje Hino. Krmiljenje sistema ECD-U2 lahko minimizira spreminjanje količine goriva med posameznimi valji ter zagotavlja manjši hrup od osnovnega za 3,5 dBA in manjše vibracije kabine za 50 odstotkov [1]. Poudariti je treba, da je z majhnimi prilagoditvami v konstrukciji okrova vbrizgalne šobe ta sistem primeren za vgradnjo v različne motorje [3] in da ima odlične karakteristike procesa vbrizgavanja. Za še nadaljnje izboljšanje teh karakteristik pa je potrebno dobro

#### 0 INTRODUCTION

In order to simultaneously improve the emission, noise, specific fuel consumption and Diesel engine performance characteristics, high pressure fuel injection as well as full injection control are required for the injection system. To meet these requirements, several injection systems have been developed for medium-duty Diesel engines. One of the most successful injection systems for truck Diesel engines is the Nippondenso's ECD-U2 system, which has been built into 8-liter Hino engines since 1995. The ECD-U2 control system minimizes the differences in fuelling between several cylinders and insures about 3.5 dBA lower noise level and 50 % less vibration of the cabin [1]. It must be pointed out that this system can also be readily adapted to various engines since only a slight modification of the nozzle holder design is necessary [3], and that this system has excellent injection process characteristics. Further improvement of these characteristics requires

poznavanje procesa vbrizgavanja in vpliva različnih elementov vbrizgalnega sistema na karakteristike vbrizgavanja. V ta namen smo za sistem ECD-U2 razvili ustrezen matematični model za numerično simuliranje procesov vbrizgavanja, ki je predstavljen v tem prispevku.

## 1 SISTEM ZA VBRIZGAVANJE GORIVA ECD-U2

Sistem ECD-U2 je sestavljen iz visokotlačne tlačilke, visokotlačne komore, vbrizgalne šobe, elektronske krmilne enote (EKE - ECU) in različnih zaznaval (sl. 1, [1] do [4]). Tlak v visokotlačni komori se prek krmilnega ventila tlačilke spreminja glede na tlačeno količino goriva visokotlačne tlačilke. Nadzira se prek zaznavala tlaka goriva in krmili glede na načrtovano vrednost v odvisnosti od obremenitve in vrtilne frekvence motorja (krmiljenje tlaka s povratno zvezo). Gorivo je pod tem tlakom vodeno do vbrizgalne šobe kakor običajno, dodatno pa še na zadnjo stran šobe.

Vbrizgana količina goriva in začetek vbrizgavanja se spreminjata v odvisnosti od velikosti tlaka na zadnji strani šobe z uporabo elektromagnetnega (3/2 solenoidnega) ventila. Začetek vbrizgavanja je krmiljen z začetkom impulza od ECU do ventila 3/2, vbrizgana količina goriva pa z dolžino trajanja tega impulza.

good knowledge of the injection process and of the influence of different injection system elements on the injection characteristics. For this purpose, a mathematical model for numerical simulation of the injection process has been developed. This model is discussed in the present paper.

## 1 THE ECD-U2 FUEL INJECTION SYSTEM

The ECD-U2 injection system is comprised of the electronically-controlled high pressure supply pump, the common rail, the electronically-controlled injectors, the electronic control unit (ECU) and various sensors (Fig.1, [1] to [4]). The common rail pressure is constantly maintained at the value required by the engine by regulating the fuel delivery from the high pressure supply pump with the pump control valve (PCV). The common rail pressure is detected by a sensor installed on the common rail. Pressure feedback control is used so that the detected common rail pressure coincides with the optimum value set in accordance with engine speed and load. The common rail pressure is applied to the pressure chamber of the nozzle and to the command chamber on the hydraulic piston interlocked with the nozzle needle.

Injection quantity and timing are controlled by the nozzle needle which is opened or closed via the hydraulic piston. The nozzle needle, in turn, is controlled by the pressure in the command chamber which is turned on and off by a three-way valve (TWV or 3/2 valve). The start of the injection is controlled by the start of TWV command pulse from ECU; meanwhile, the fuelling is controlled by the duration of this pulse.

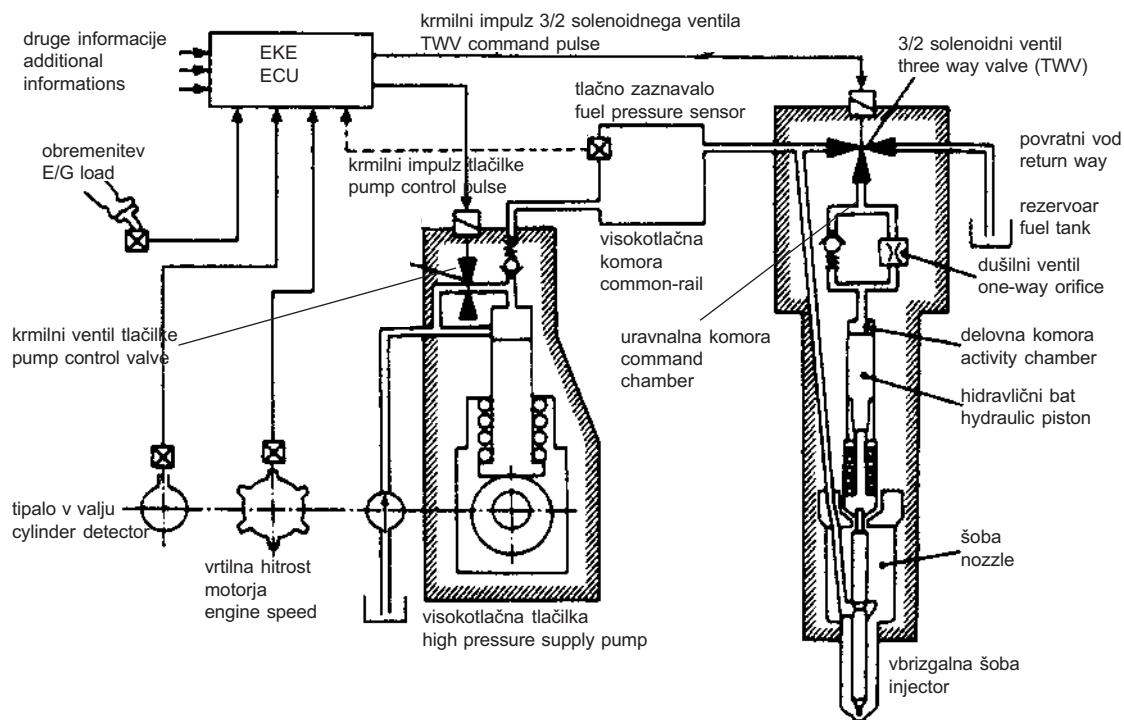

Sl. 1. Shema sistema ECD-U2  
Fig. 1. Schematic of the system ECD-U2

Solenoidni ventil 3/2 je aktiviran, ko dobi ustrezeni krmilni impulz iz ECU. Takrat spusti gorivo iz prostora nad hidravličnim batom v povratni vod. V tem trenutku se tlak pod solenoidnim ventilom v uravnavni komori hitro zniža od tlaka v visokotlačni komori do atmosferskega tlaka, medtem ko se tlak v delovni komori pod dušilnim ventilom znižuje postopoma zaradi dušenja skozi majhno izvrtino dušilnega ventila. Zaradi tega postopno narašča dvig igle, kar je ugodno za proces zgorevanja. Tako dobimo t.im. delta tip karakteristike vbrizgavanja.

Pri sistemu ECD-U2 je namesto solenoidnega ventila 3/2 mogoča tudi uporaba izvedbe 2/2 [6] (sl. 2). Pri solenoidnem ventilu 2/2 je dejanski pretočni prerez skozi izvrtino, ki povezuje visokotlačno z uravnavno komoro, nespremenljiv. Temu ustrezne so razlike pri poteku karakteristike vbrizgavanja.

### 3/2 solenoidni ventil 3/2 solenoid valve

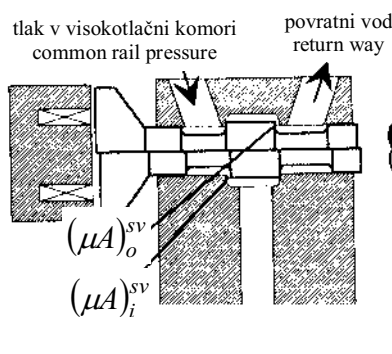

### 2/2 solenoidni ventil 2/2 solenoid valve

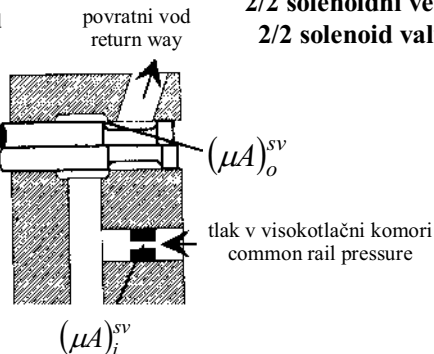

Sl. 2. Shema 3/2 in 2/2 solenoidnih ventilov  
Fig. 2. Schematic of the 3/2 and 2/2 solenoid valves

Za doseg stopničastega tipa karakteristike vbrizgavanja se namesto dušilnega ventila uporablja hidravlični ventil, (sl. 3) [5]. V tem primeru je reža med hidravličnim batom in ventilom predvig igle.

A boot shape injection rate is obtained using the boot (hydraulic) valve, placing the return valve in an ordinary injector. This boot valve is installed below the solenoid valve (Fig. 3) [5]. The gap between the boot valve and the hydraulic piston is the adjustable pre-lift.

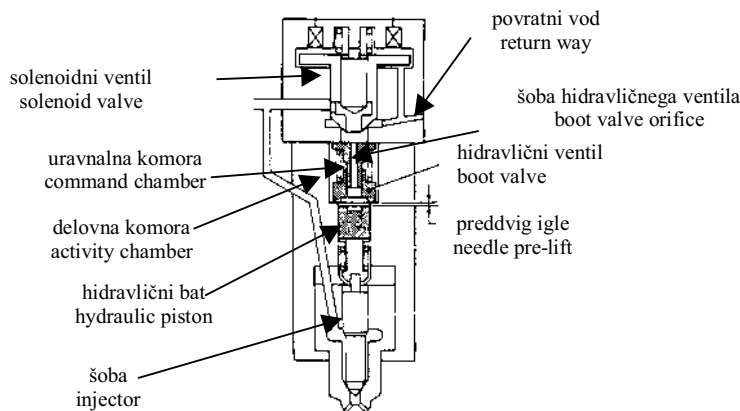

Sl. 3. Shema vbrizgalne šobe s hidravličnim ventilom  
Fig. 3. Schematic of the injector nozzle with hydraulic valve

Pri zagonu solenoidnega ventila je ustvarjena povezava med hidravličnim batom in povratnim vodom. Tlak v komandni komori zato hitro pade in omogoči dvig igle do velikosti preddviga. Tedaj je hidravlični ventil v dotiku s hidravličnim ventilom. Igla ostane na ravni preddviga, dokler ni premagana sila vzmeti. Takrat začne tlak v delovni komori upadati zaradi iztekanja goriva skozi izvrtino v hidravličnem ventilu. Rezultat tega iztekanja je nadaljnji dvig igle vbrizgalne šobe. Ko se nato solenoidni ventil izklopi, se tlak v uravnavni komori hitro zviša in deluje neposredno na hidravlični bat. Igla se naglo spusti na sedež.

## 2 NUMERIČNO SIMULIRANJE PROCESOV V VBRIZGALNI ŠOBI

V matematičnem modelu je predpostavljen nespremenljiv tlak v visokotlačni komori, ki je enak tlaku vbrizgavanja  $p_{cr}$  [6]. V nadaljevanju so predstavljene samo osnovne enačbe za simuliranje procesov v vbrizgalni šobi sistema ECD-U2 z uporabo dušilnega ventila in potrebne korekcije v primeru uporabe hidravličnega ventila.

### 2.1 Vbrizgalna šoba z uporabo dušilnega ventila

Kontinuitetna enačba za uravnavno komoro je predstavljena z naslednjim izrazom:

$$\begin{aligned} \frac{dp_{cc}}{dt} \frac{V_{cc}}{E} = & (\mu A)_i^{sv} \sqrt{\frac{2}{\rho} |p_{cr} - p_{cc}|} \operatorname{sgn}(p_{cr} - p_{cc}) + \\ & + (\mu A)_o^{sv} \sqrt{\frac{2}{\rho} |p_{am} - p_{cr}|} \operatorname{sgn}(p_{am} - p_{cr}) - \\ & - A_{sv} v_{sv} - (\mu A)_{rv} \sqrt{\frac{2}{\rho} |p_{cc} - p_{ac}|} \operatorname{sgn}(p_{cc} - p_{ac}) - A_{rv} v_{rv} \end{aligned} \quad (1),$$

kjer so  $p$  - tlak,  $V$  - prostornina,  $E$  - modul elastičnosti,  $t$  - čas,  $\mu A$  - dejanski pretočni prerez,  $A$  - prerez,  $v$  - hitrost,  $\rho$  - gostota. Indeks pa označuje element ali prostor, na katerega se posamezna količina nanaša: cc - uravnavna komora, sv - solenoidni ventil, i - vstop, cr - visokotlačna komora, o - izstop, am - okolica in rv - dušilni ventil.

Kontinuitetno enačbo za delovno komoro lahko zapišemo:

$$\frac{dp_{ac}}{dt} \frac{V_{ac}}{E} = (\mu A)_{rv} \sqrt{\frac{2}{\rho} |p_{cc} - p_{ac}|} \operatorname{sgn}(p_{cc} - p_{ac}) + A_{rv} v_{rv} + A_{ap} v_n \quad (2),$$

kjer se indeks ap nanaša na hidravlični bat, n pa na iglo vbrizgalne šobe.

V enačbah gibanja dušilnega ventila:

$$\frac{dh_{rv}}{dt} = \begin{cases} 0, & F_{rv} \geq 0 \quad \text{in} \quad h_{rv} = h_{maks}^{rv} \\ 0, & F_{rv} \leq 0 \quad \text{in} \quad h_{rv} = 0 \\ v_{rv}, & \text{v drugih primerih / otherwise} \end{cases} \quad (3),$$

When the solenoid valve is energized, the command chamber is connected with the fuel tank. The pressure in the command chamber is quickly reduced and the nozzle needle rises to the height of the needle pre-lift. At this moment, the boot valve comes into contact with the hydraulic piston. The nozzle needle is temporarily stopped at a small pre-lift point as long as the spring force holds. By that time, the pressure in the activity chamber starts to reduce because of the fuel flowing through the boot orifice. This results in further rising of nozzle needle. When the solenoid valve is de-energized, the pressure in the command chamber quickly increases, directly influencing the hydraulic piston. The nozzle needle is closed quickly, and a sharp termination of the injection is obtained.

## 2 THE NUMERICAL SIMULATION OF THE PROCESSES IN THE INJECTOR

In the mathematical model, the common rail pressure is assumed to be constant and equal to the injection pressure,  $p_{cr}$  [6]. In the following section, the basic equations for simulation of the processes in the injector of the ECD-U2 system are presented. The first set of equations assumes the use of the return valve, while the necessary corrections for the boot valve are given in the second set.

### 2.1 Injector using the return valve

The equation of continuity for the command chamber is written as follows:

where the symbol  $p$  denotes the pressure,  $V$  - the volume,  $E$  - the modulus of elasticity,  $t$  - time,  $\mu A$  - the effective flow area,  $A$  - the area,  $v$  - the velocity and  $\rho$  - the density. The indices denote the element or a corresponding chamber as follows: cc - command chamber, sv - solenoid valve, i - inlet, cr - "common rail", o - outlet, am - ambient and rv - return valve.

Equation of continuity for the activity chamber is written as

where the indices ap and n are related to the hydraulic piston and to the nozzle needle, respectively.

In the equations of motion of the return valve:

$$\frac{dv_{rv}}{dt} = \begin{cases} 0, & F_{rv} \geq 0 \text{ in } h_{rv} = h_{maks}^{rv} \\ 0, & F_{rv} \leq 0 \text{ in } h_{rv} = 0 \\ F_{rv} / m_{rv}, & \text{v drugih primerih / otherwise} \end{cases} \quad (4)$$

pomeni simbol

$F_{rv} = A_{rv}(p_{cc} - p_{ac}) - F_0^{rv} - C_{rv}(h_{rv} + h_n)$  silo na dušilni ventil,  $h$  - dvig,  $m$  - maso gibajočih se delov,  $F_0$  - silo prednapetja vzmeti in  $C$  - togost vzmeti.

Enačbi gibanja igle vbrizgalne šobe sta zapisani z naslednjima izrazoma:

of the return valve, the symbol

$F_{rv} = A_{rv}(p_{cc} - p_{ac}) - F_0^{rv} - C_{rv}(h_{rv} + h_n)$  denotes the force on the return valve, where  $h$  is the lift,  $m$  is the mass of the moving parts,  $F_0$  is the pre-loading force and  $C$  is the spring stiffness.

The equations of motion, related to the nozzle needle, are given by the following expressions:

$$\frac{dh_n}{dt} = \begin{cases} 0, & F_n \geq 0 \text{ in } h_n = h_{maks}^n \\ 0, & F_n \leq 0 \text{ in } h_n = 0 \\ v_n, & \text{v drugih primerih / otherwise} \end{cases} \quad (5),$$

$$\frac{dv_n}{dt} = \begin{cases} 0, & F_n \geq 0 \text{ in } h_n = h_{maks}^n \\ 0, & F_n \leq 0 \text{ in } h_n = 0 \\ F_n / m_{n+ap}, & \text{v drugih primerih / otherwise} \end{cases} \quad (6),$$

kjer je sila na iglo:

where represents the force acting on the needle:

$$F_n = p_{cr}(A_{st}^n - A_{se}^n) + p_{sac}A_{sc}^n - p_{ac}A_{ap} - F_0^n - C_n h_n - F_0^{rv} - C_{rv}(h_{rv} + h_n)$$

$$p_{sac} = \frac{k^2}{1-k^2}(p_{cr} - p_{am}) + p_{am}, \quad k = \frac{(\mu A)_{in}}{(\mu A)_{maks}^n}$$

indeks in označuje vbrizgalno šobo, st steblo in se sedež igle.

Karakteristiko vbrizgavanja  $\dot{q}$  določimo z izrazom:

the index  $n$  denotes the injector,  $st$  the needle steam and  $se$  the needle seat.

The injection rate  $\dot{q}$  is determined as follows:

$$\dot{q} = (\mu A)_{in} \sqrt{\frac{2}{\rho}(p_{cr} - p_{am})} \quad (7).$$

## 2.2 Vbrizgalna šoba z uporabo hidravličnega ventila

## 2.2 Injector using the boot valve

V primeru uporabe hidravličnega ventila (indeks hv) enačbo (1) zapišemo v odvisnosti od lege igle glede na predvig igle  $h_{nl}$ :

In the case of using the boot valve (index hv), the equation (1) is written with dependence upon the nozzle needle pre-lift  $h_{nl}$  as:

$$h_n < h_{nl} : \frac{dp_{cc}}{dt} \frac{V_{cc}}{E} = (\mu A)_i^{sv} \sqrt{\frac{2}{\rho} |p_{cr} - p_{cc}| \text{sgn}(p_{cr} - p_{cc})} + (\mu A)_o^{sv} \sqrt{\frac{2}{\rho} |p_{am} - p_{cr}| \text{sgn}(p_{am} - p_{cr})} - A_{sv} v_{sv} - (\mu A)_{hv} \sqrt{\frac{2}{\rho} |p_{cc} - p_{ac}| \text{sgn}(p_{cc} - p_{ac})} + A_{ap} v_n \quad (8),$$

or:

oziroma:

$$h_n \geq h_{nl} : \frac{dp_{cc}}{dt} \frac{V_{cc}}{E} = (\mu A)_i^{sv} \sqrt{\frac{2}{\rho} |p_{cr} - p_{cc}| \text{sgn}(p_{cr} - p_{cc})} + (\mu A)_o^{sv} \sqrt{\frac{2}{\rho} |p_{am} - p_{cr}| \text{sgn}(p_{am} - p_{cr})} - A_{sv} v_{sv} - (\mu A)_{hv} \sqrt{\frac{2}{\rho} |p_{cc} - p_{ac}| \text{sgn}(p_{cc} - p_{ac})} - A_{hv} v_{hv} \quad (9).$$

Kontinuitetna enačba (2) ima sedaj nekoliko spremenjeno obliko:

The equation of continuity (2) has a new adapted form:

$$\frac{dp_{ac}}{dt} \frac{V_{ac}}{E} = (\mu A)_{hv} \sqrt{\frac{2}{\rho}} |p_{cc} - p_{ac}| \operatorname{sgn}(p_{cc} - p_{ac}) + A_{hv} v_{hv} \quad (10).$$

Enačbi gibanja hidravličnega ventila zapišemo podobno kakor pri dušilnem ventilu (enačbi (3) in (4)). Silo na hidravlični ventil  $F_{hv}$  pa določimo v odvisnosti od lege igle glede na preddvig:

$$h < h_{nl}: F_{hv} = p_{cc} A_{hv}^* - p_{ac} A_{hv}^{**} - F_0^{hv} - h_{hv} C_{hv}$$

$$h \geq h_{nl}: F_{hv} = p_{cr} (A_{st}^n - A_{se}^n) + p_{sac} A_{se}^n + p_{cc} A_{hv}^* - p_{ac} A_{hv}^{**} - h_{hv} C_{hv} - h_n C_n - F_0^{hv} - F_0^n$$

V enačbah (5) in (6), ki opisujejo gibanje igle vbrizgalne šobe, silo na iglo vbrizgalne šobe prav tako določamo glede na preddvig, in sicer:

$$h < h_{nl}: F_n = p_{cr} (A_{st}^n - A_{se}^n) + p_{sac} A_{se}^n - p_{cc} A_{ap} - F_0^n - h_n C_n$$

$$h \geq h_{nl}: F_n = p_{cr} (A_{st}^n - A_{se}^n) + p_{sac} A_{se}^n - p_{cc} A_{hv} - p_{ac} A_{hv}^{**} - h_{hv} C_{hv} - h_n C_n - F_0^{hv} - F_0^n$$

The equations of motion for the boot valve are written similarly as for the return valve ((3) and (4)). The force on the boot valve  $F_{hv}$  is determined with dependence upon the needle position with respect to needle pre-lift:

In equations (5) and (6), which determine the movement of the needle nozzle, the force on the needle can be determined as follows:

### 3 REZULTATI

Obravnavane so različne izvedbe sistema ECD-U2. Izračuni so izvedeni za premera izvrtine dušilne šobe  $d_{rv} = 0,3$  mm in  $d_{rv} = 0,2$  mm z uporabo solenoidnih ventilov 3/2 in 2/2, za premera izvrtine hidravličnega ventila  $d_{hv} = 0,2$  mm in  $d_{hv} = 0,3$  mm s preddvigom igle vbrizgalne šobe  $h_{nl} = 0,07$  mm in  $h_{nl} = 0,14$  mm. Preostali vhodni podatki so v vseh primerih enaki [2]. V vseh primerih znaša vbrizgana količina goriva  $177$  mm<sup>3</sup>/krožni proces pri vrtilni hitrosti  $1000$  min<sup>-1</sup> in tlaku vbrizgavanja  $100$  MPa. V nadaljevanju so prikazani poteki tlaka v uravnalni  $p_{cc}$  in v delovni  $p_{ac}$  komori ter karakteristike vbrizgavanja  $\dot{q}$ .

Na sliki 4 so prikazane osnovne karakteristike sistema z uporabo dušilnega ventila s premerom izvrtine  $d_{rv} = 0,3$  mm ter z uporabo solenoidnega ventila 3/2 pri enostopenjskem vbrizgu.

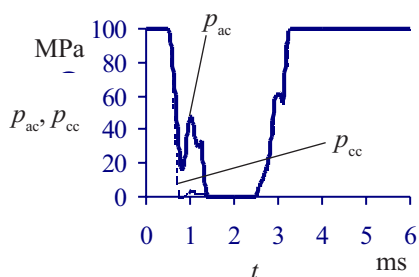

Sl. 4. Karakteristike procesa vbrizgavanja ( $d_{rv} = 0,3$  mm, 3/2 sv)  
Fig. 4. Characteristics of the injection process ( $d_{rv} = 0,3$  mm, 3/2 sv)

Prikazani rezultati na sliki 4, dobljeni z matematičnim modelom, potrjujejo, da dušilni ventil omogoča delta tip karakteristike vbrizgavanja. Na obliko te karakteristike v veliki meri vpliva premer izvrtine dušilnega ventila. Rezultati pri enostopenjskem vbrizgu so prikazani na sliki 5.

### 3 RESULTS

Several different configurations of the ECD-U2 system are considered. The calculations are performed for two different one-way orifice diameters ( $d_{rv} = 0.3$  mm and  $d_{rv} = 0.2$  mm) used with both types of the solenoid valve 3/2 and 2/2, and for boot orifice diameters ( $d_{hv} = 0.2$  mm and  $d_{hv} = 0.3$  mm) with nozzle needle pre-lifts  $h_{nl} = 0.07$  mm and  $h_{nl} = 0.14$  mm. All other input data remain the same [2]. In all cases, the fuelling is  $177$  mm<sup>3</sup>/cycle at the pump speed of  $1000$  min<sup>-1</sup> and injection pressure of  $100$  MPa. The following diagrams show the pressure in the command chamber  $p_{cc}$  and the pressure in the activity chamber  $p_{ac}$  as well as the shape of the injection rate history  $\dot{q}$ .

In Fig. 4, the basic characteristics of the injection system are shown by using the return valve with one-way orifice diameter of  $d_{rv} = 0.3$  mm and the 3/2 solenoid valve by one-stage injection.

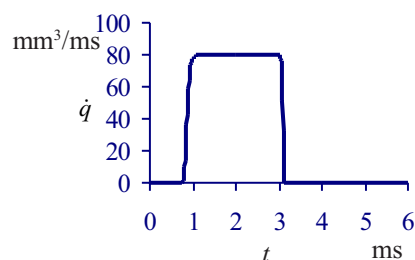

The results presented in Fig. 4, obtained by the proposed mathematical model, confirm the fact that the return valve enables the delta type of the injection rate history. The shape of this delta injection rate history mainly depends upon the diameter of the one-way orifice. The obtained results of one-stage injection are presented in Fig. 5.

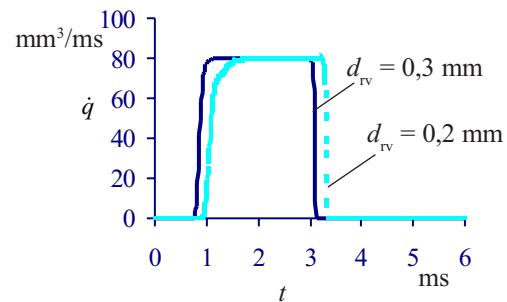
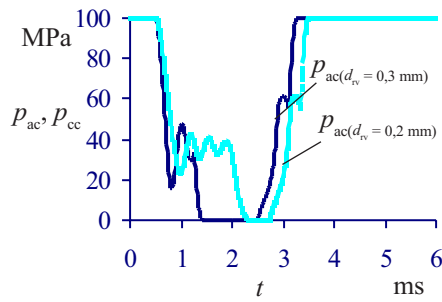

Sl. 5. Vpliv različnega premera izvrtine dušilnega ventila (3/2 sv)  
Fig. 5. The influence of the different one-way orifice diameters (3/2 sv)

Na sliki 6 je prikazan vpliv različnih tipov solenoidnih ventilov. Kakor je razvidno, solenoidni ventil 3/2 omogoča nekoliko bolj strm začetek in konec karakteristike vbrizgavanja od ventila 2/2. To je posledica hitrejšega dviga in spusta igle vbrizgalne šobe oziroma poteka tlaka v uravnlalni in delovni komori.

Fig. 6 it shows the influence of different types of solenoid valves. It is evident that the 3/2 solenoid valve enables somewhat faster start and end of the injection rate history than the 2/2 valve. This is the consequence of the needle opening and closing faster as well as the distribution of pressures in the command and the activity chamber.

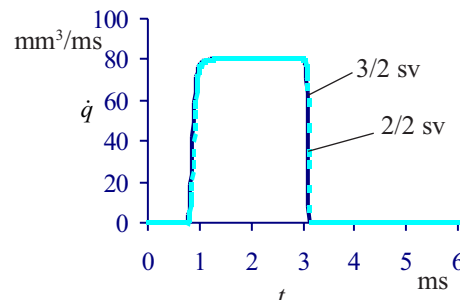
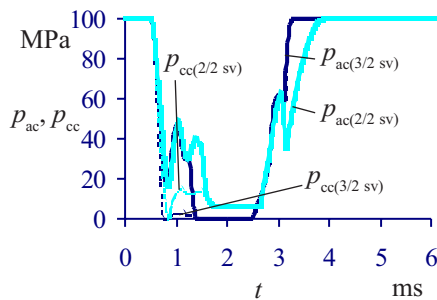

Sl. 6. Vpliv različnih tipov solenoidnih ventilov ( $d_{rv} = 0,3 \text{ mm}$ )  
Fig. 6. The influence of the different types of the solenoid valves ( $d_{rv} = 0.3 \text{ mm}$ )

Na stopničasto karakteristiko vbrizgavanja v primeru uporabe hidravličnega ventila zelo vplivata premer izvrtine ventila in predvig igle vbrizgalne šobe. To dejstvo potrjujejo tudi rezultati matematičnega modela, prikazani na slikah 7 in 8 za enostopenjski vbrizg.

The boot type of injection rate, obtained by using the boot valve, is influenced to a great extent by the boot orifice diameter and by the nozzle needle pre-lift. This fact is confirmed by the numerical results of the proposed mathematical model, which are presented in Fig. 7 and Fig. 8 for the one-stage injection.

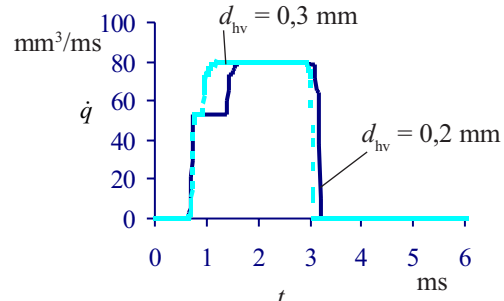
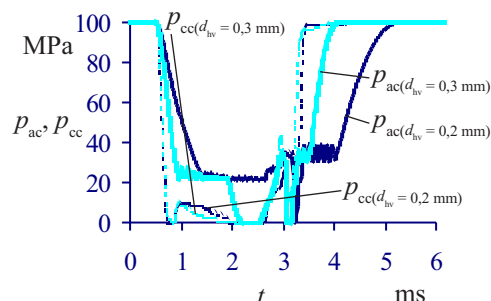

Sl. 7. Vpliv premera izvrtine hidravličnega ventila ( $h_{nl} = 0,07 \text{ mm}$ , 3/2 sv)  
Fig. 7. The influence of the nozzle of the hydraulic valve diameters ( $h_{nl} = 0.07 \text{ mm}$ , 3/2 sv)

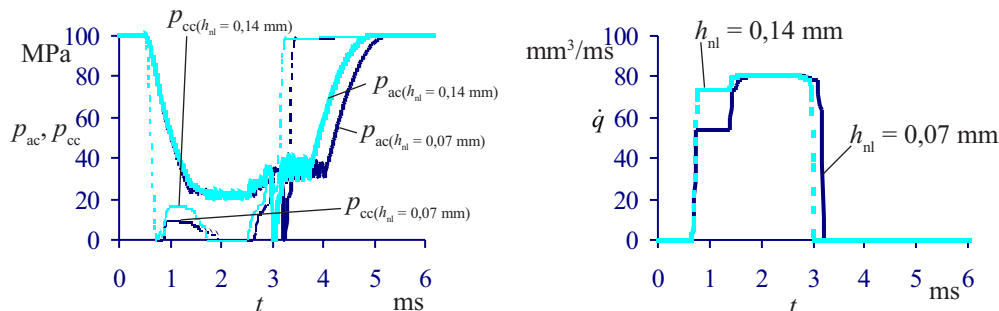

Sl. 8. Vpliv predviga igle vbrizgalne šobe ( $d_{hv} = 0,02 \text{ mm}$ , 3/2 sv)  
 Fig. 8. The influence of the needle prelift ( $d_{hv} = 0.02 \text{ mm}$ , 3/2 sv)

Sistem ECD-U2 omogoča, v katerikoli zgoraj opisani različici, tudi večstopenjsko vbrizgavanje. V primeru uporabe dušilnega ventila so prikazani rezultati za tristopenjski vbrizg (sl. 9), v primeru uporabe hidravličnega ventila pa za dvostopenjski vbrizg (sl. 10).

The ECD-U2 system also enables in all of the above-mentioned configurations a multi-stage injection. In the case of using the return valve, the results for three-stage injection are shown in Fig. 9. In the case of using the boot valve, the results for two-stage injection are given in Fig. 10.

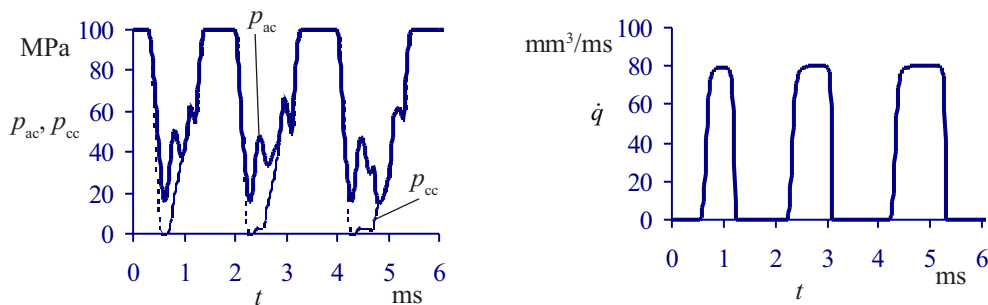

Sl. 9. Karakteristike vbrizgavanja pri tristopenjskem vbrizgu ( $d_{rv} = 0,3 \text{ mm}$ , 3/2 sv)  
 Fig. 9. The injection characteristics using the three-stage injection ( $d_{rv} = 0.3 \text{ mm}$ , 3/2 sv)

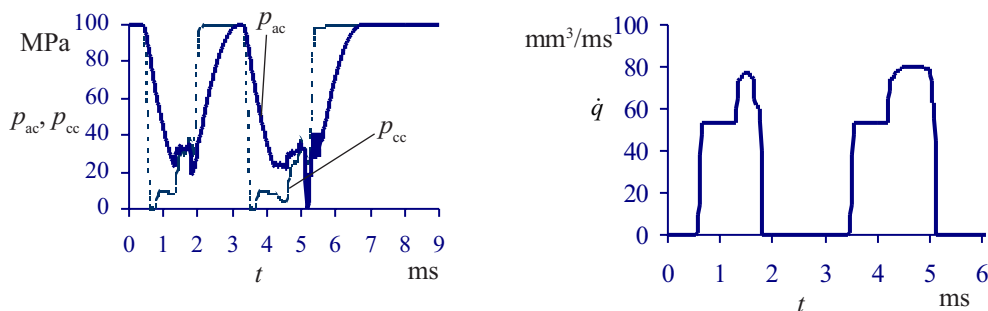

Sl. 10. Karakteristike vbrizgavanja pri dvostopenjskem vbrizgu ( $d_{hv} = 0,2 \text{ mm}$ , 3/2 sv,  $h_{nl} = 0,07 \text{ mm}$ )  
 Fig. 10. The injection characteristics using the two-stage injection ( $d_{hv} = 0.2 \text{ mm}$ , 3/2 sv,  $h_{nl} = 0.07 \text{ mm}$ )

Grobo oceno procesa vbrizgavanja lahko podamo na podlagi prikazanih diagramov, slike 4 do 10 in vrednosti, zbranih v preglednici 1.

A rough estimation of the injection process can be made by using the diagrams presented in Fig. 4 to 10, and the characteristics values assembled in Table 1.

Najučinkovitejšo delta karakteristiko vbrizgavanja lahko dobimo z izbiro ustreznega premera izvrtine dušilnega ventila in ob uporabi solenoidnega ventila 3/2, primer 2 v preglednici 1. V primeru stopničaste enostopenjske karakteristike vbrizgavanja pa daje najugodnejše rezultate izvedba sistema ECD-U2, opisana v primeru 6. Optimalna

The very efficient delta shape of the injection rate history can be obtained with the choice of an appropriate one-way orifice diameter using the 3/2 solenoid valve (case 2 in Table 1). For the boot shape of the injection rate history for one-stage injection, the configuration of ECD-U2 system, given



oblika stopničaste karakteristike se doseže z optimalno izbiro velikosti preddviga igle vbrizgalne šobe in premera izvrtine v hidravličnem ventilu. V primerih 7 in 8 pa so potrjene splošno znane prednosti večstopenjskega vbrizgavanja. V preglednici 1 je podan tudi čas odprtja solenoidnega ventila  $t_{sv}^o$ , ki je potreben, da se v vseh primerih zagotovi enaka količina vbrizganega goriva.

in case 6, offers the best results. The optimal shape of the boot type of injection rate history can be obtained by using appropriate values of the nozzle needle pre-lift and the boot orifice diameter. Cases 7 and 8 confirm the well-known advantages of multi-stage injection. In Table 1, the solenoid valve opening time ( $t_{sv}^o$ ), necessary to assure the same fuelling in all discussed cases, is also given.

Preglednica 1. Čas vbrizgavanja  $t_{inj}$  v ms in srednja hitrost vbrizgavanja  $\bar{q}$  v  $mm^3/ms$   
Table 1. Injection time  $t_{inj}$  in ms and mean injection rate  $\bar{q}$  in  $mm^3/ms$

PRIMER EXAMPLE	1	2	3	4	5	6	7	8
$d_{rv}$ mm	0,3	0,2	0,3	-	-	-	0,3	-
$d_{hv}$ mm	-	-	-	0,2	0,3	0,2	-	0,2
$h_{nl}$ mm	-	-	-	0,07	0,07	0,14	-	0,07
tip/type sv	3/2	3/2	2/2	3/2	3/2	3/2	3/2	3/2
$t_{sv}^o$ ms	2,00	2,23	2,15	2,23	2,03	2,00	1,65	2,16
$t_{inj}$	3,11	3,05	3,15	3,20	3,05	3,02	2,64	2,93
$\bar{q}$	57,1	58,2	56,4	55,4	58,2	58,8	67,0	60,0

#### 4 SKLEP

Na temelju numeričnih rezultatov, ki so bili preverjeni tudi v podjetju Bosch [2], lahko povzamemo:

- Uporaba dušilnega ventila omogoča različne delta tipe karakteristike vbrizgavanja v odvisnosti od premera izvrtine dušilnega ventila, medtem ko uporaba hidravličnega ventila zagotavlja različne tipe stopničaste karakteristike vbrizgavanja v odvisnosti od premera izvrtine hidravličnega ventila in preddviga igle vbrizgalne šobe.
- Solenoidni ventil 3/2 daje ugodnejše karakteristike procesa vbrizgavanja kakor ventil 2/2, saj omogoča hitrejši konec vbrizgavanja in s tem manjšo emisijo saj.

#### ZAHVALA

Avtorica se zahvaljuje Ministrstvu za znanost in tehnologijo Republike Slovenije (Pogodba št. S2-7994-0795-96) za financiranje raziskovalnega projekta.

#### 4 CONCLUSION

On the basis of the numerically obtained results, which were confirmed by the company Bosch [2], it can be concluded:

- The use of the return valve enables different shapes of the delta injection rate history depending upon the one-way orifice diameter, while the use of the boot valve assures several shapes of boot injection rate histories depending upon the boot orifice diameter and the nozzle needle pre-lift.
- The 3/2 solenoid valve gives more suitable injection characteristics than the 2/2 solenoid valve because of faster termination of injection and consequently smaller soot emission.

#### ACKNOWLEDGEMENTS

The author wishes to acknowledge the Ministry of Science and Technology of the Republic of Slovenia (Contract No. S2-7994-0795-96) for funding this research project.

5 LITERATURA  
5 REFERENCES

- [1] Johnson, P. (1996) Common rail injection developed for Hino engine. *High Speed Diesels&Drives*, 42-44.
- [2] Kegl, B. (1996) A simple numerical simulation of the processes in common rail injection system. Report BK/EM-2/97. Technische Universität Braunschweig, Institut für Verbrennungskraftmaschinen.
- [3] Miyaki, M., Fujisa, H., Masuda, A., Y, Yamamoto, Development of new electronically controlled fuel injection system ECD-U2 for Diesel engines, SAE 910252.
- [4] Nishijima, Y., Itoh, S., T. Iwanaga (1995) Injection rate shaping technology with common rail fuel system (ECD-U2). Seminar on Diesel fuel injection systems, *MEP London*, 147-161.
- [5] Omori, T. (1992) Electronic controlled fuel injection system for clean Diesel engine. *ATZ/MTZ Sonderheft Motor und Umwelt'92*, 28-30.
- [6] Prescher, K., Bauer, W., W. Schaffitz (1994) Common rail Einspritzsysteme mit drehzahlunabhängiger Charakteristik und hohem Einspritzdruck ein Zukunftspotential für den Dieselmotor. *VDI Verlag Reihe 12: Verkehrstechnik/Fahrzeugtechnik Nr. 205*.

Naslov avtorice: doc. dr. Breda Kegl  
Fakulteta za strojništvo  
Univerze v Mariboru  
Smetanova 17  
2000 Maribor

Author's Address: Doc.Dr. Breda Kegl  
Faculty of Mech. Engineering  
University of Maribor  
Smetanova 17  
2000 Maribor, Slovenia

Prejeto: 15.10.1999  
Received:

Sprejeto: 3.12.1999  
Accepted: